



# *Tool Catalog*

NO.231





# For Your Safety

## Spanners

- Use the correct tool for a bolt or nut.
- Please insert a spanner or wrench all the way into the bolt or nut and engage properly.
- A tool might slip and come off from a bolt or nut when it is strained too hard.
- Do not insert a pipe or other object to extend the tool.
- Do not hit a tool with a hammer or other objects, except for impact tools such as box-ended and single-ended wrenches.
- For your safety, please wear safety goggles, earplugs, safety hats and safety footwear when using impact tools such as box-ended and single-ended wrenches.
- Please be careful not to get your fingers caught in the hole of the handle.
- Do not use if a tool is cracked, worn away, or deformed.
- Do not utilize a tool as a hammer.

## Hexagon Key Wrenches

- Use the correct tool for a bolt or nut.
- Please insert a hex key all the way into a hexagon bolt and engage properly.
- A tool might slip and come off from a bolt or nut when it is strained too hard.
- Do not insert a pipe or other object to extend the tool.
- Do not use if a tool is cracked, worn away, or deformed.
- Do not hit a tool with a hammer or other objects.
- Do not utilize a tool as a hammer.

## Torque Wrenches

- Use the correct tool for a bolt or nut.
- Please insert a spanner or wrench all the way into the bolt or nut and engage properly.
- A tool might slip and come off from a bolt or nut when it is strained too hard.
- Please completely insert square drive.
- Do not exceed the maximum torque.
- Do not use to loosen bolts or nuts.
- Do not insert a pipe or other object to extend the tool.
- Do not use if a tool is cracked, worn away, or deformed.
- Do not hit a tool with a hammer or other objects.
- Do not utilize a tool as a hammer.
- Please read the instructions carefully before use.
- Please perform regular calibration to keep the tools accurate.

## Sockets

- Use the correct tool for a bolt or nut.
- Please insert a spanner or wrench all the way into the bolt or nut and engage properly.
- A tool might slip and come off from a bolt or nut when it is strained too hard.
- Please completely insert square drive.
- Please use dedicated sockets and accessories for power tools such as impact wrenches.
- For your safety, please wear safety goggles, earplugs, safety hats and safety footwear when using impact wrenches.
- Do not use if a tool is cracked, worn away, or deformed.
- Do not hit a tool with a hammer or other objects.
- Do not utilize a tool as a hammer.
- Please use a specified O-ring or pin and set on an impact wrench securely.
- Do not connect more than two extension bars or adapters.

## T-Handled, Y-Shape, Tire Wrenches

- Use the correct tool for a bolt or nut.
- Please insert a spanner or wrench all the way into the bolt or nut and engage properly.
- A tool might slip and come off from a bolt or nut when it is strained too hard.
- Do not insert a pipe or other object to extend the tool.
- Do not use if a tool is cracked, worn away, or deformed.
- Do not hit a tool with a hammer or other objects.
- Do not utilize a tool as a hammer.

## Pliers

- Please be careful not to get your hands or fingers caught in a handgrip.
- Please adjust and set an opening of pliers correctly.
- Do not use if a tool is cracked, worn away, or deformed.
- Do not hit a tool with a hammer or other objects.
- Do not utilize a tool as a hammer.

## Hammer

- For your safety, please wear safety goggles, earplugs, safety hats and safety footwear.
- Do not use if the tool is unstable, cracked, worn away or deformed.
- Please hit the striking surface vertically.

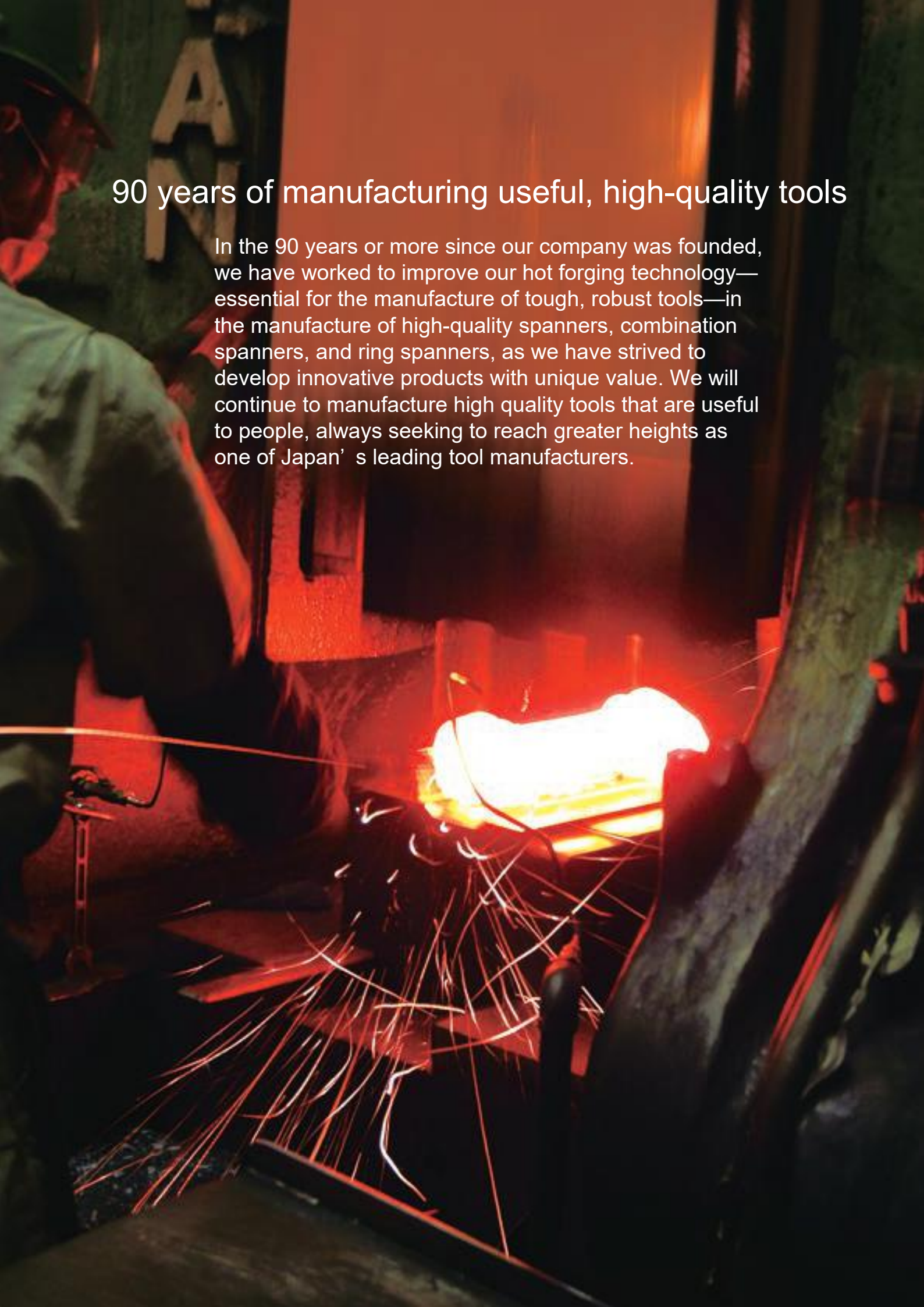

## 90 years of manufacturing useful, high-quality tools

In the 90 years or more since our company was founded, we have worked to improve our hot forging technology—essential for the manufacture of tough, robust tools—in the manufacture of high-quality spanners, combination spanners, and ring spanners, as we have strived to develop innovative products with unique value. We will continue to manufacture high quality tools that are useful to people, always seeking to reach greater heights as one of Japan's leading tool manufacturers.





Single Open End Spanner  
Double Open End Spanner



Combination Wrench

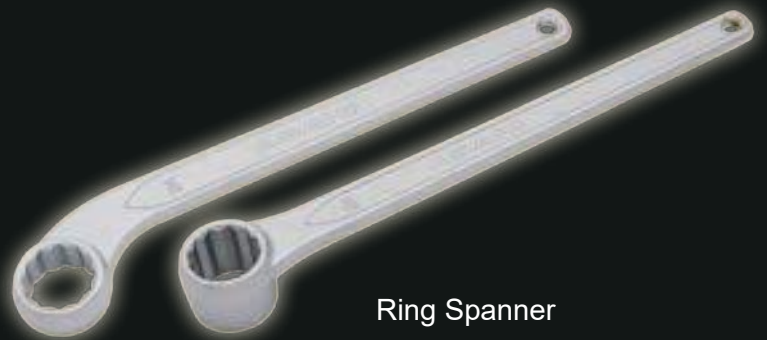

Ring Spanner



Striking Face Ring Spanner



Hook Spanner

## A Beautiful Shape Comes from Lightness

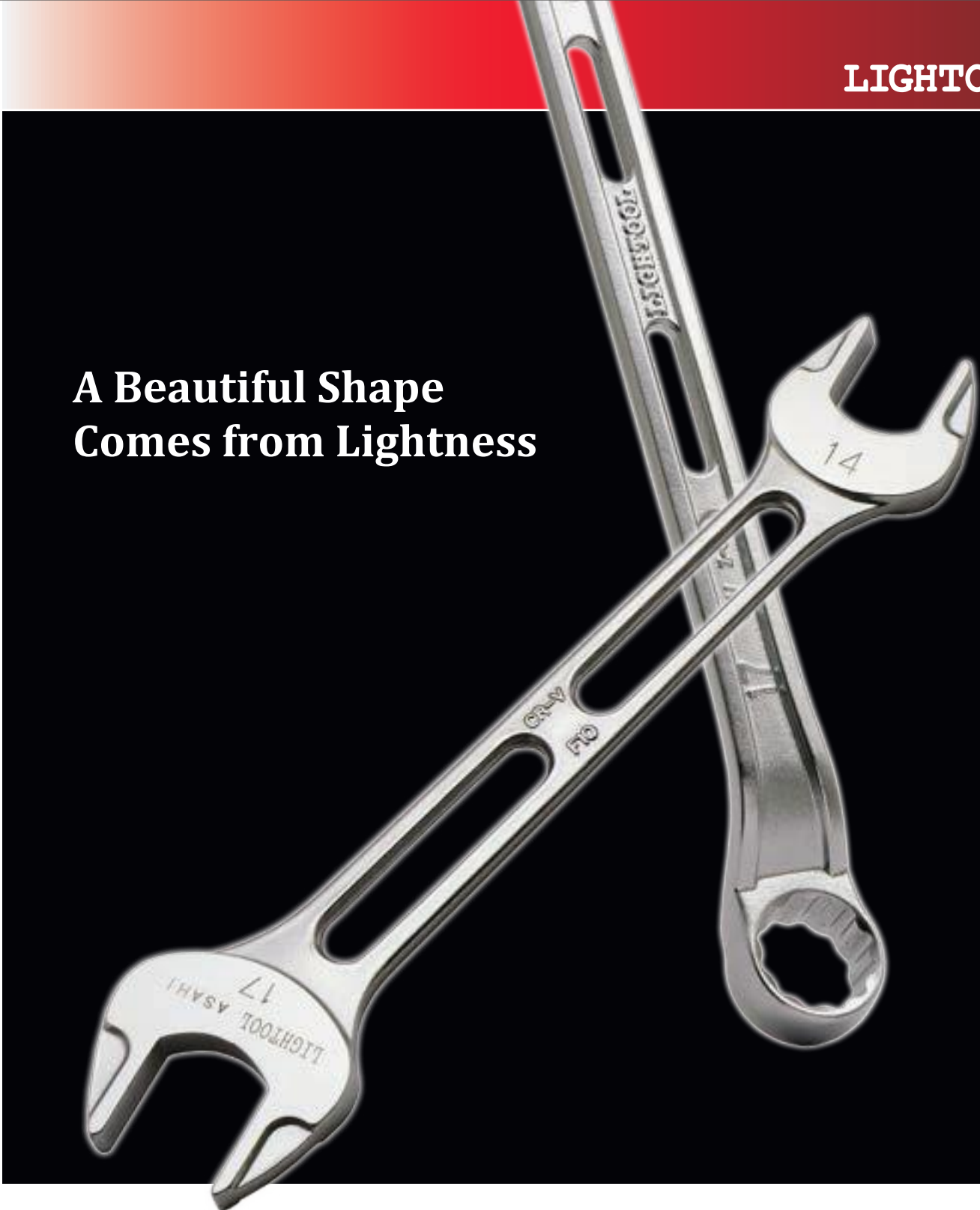

### Lightweight Yet Durable

Highly portable and workable tools are suitable for work in high places or for long periods of use. Tested design and high-quality forging technology have produced lightweight yet durable tools, which meet the JIS regulations.

Comparison with our conventional products

Size	Normal	LIGHTOOL	Percentage
5.5 × 7	30g	10g	67%
8 × 10	30g	15g	50%
11 × 13	50g	40g	20%
12 × 14	70g	50g	29%
17 × 19	120g	100g	17%
22 × 24	215g	180g	16%

### A Uniquely Shaped Head



A uniquely shaped head is lightweight yet durable.  
(LSX/LCW/LCWU)

### A Wide Range of Sizes and Shapes

- LSX Double Open End Spanner 11 sizes (5.5×7mm—22×24mm)
- LOF Offset Wrench 10 sizes (8×10mm—22×24mm)
- LCW Combination Wrench 21 sizes (5.5mm—32mm)
- LCWU Combination Wrench 11 sizes (5.5mm—17mm)
- LVR Ratchet Handle 2 type (□9.5mm, □12.7mm)

### A Compact Head

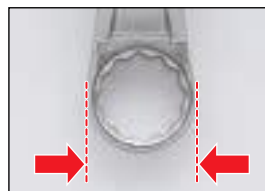

A ring spanner head is smaller than ever before and suitable for working in confined spaces.  
(LOF)

# ASAHI's New Generation Tools



## Innovative Design

A sleek, timeless design with a streamlined curved surface of a neck and a tapered shape head. A handle and a head make a beautiful contrast.



## High Workability

The curved surface of the neck fits your hand and produces great workability.

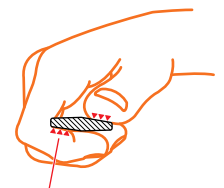
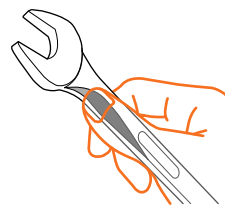

Easy-to-grasp-handle

## A Wide Range of Sizes and Shapes

- SL Double Open End Spanner 15 sizes (5.5×7mm—22×24mm)
- CL Combination Wrench 22 sizes (5.5mm—32mm)
- OL Offset Wrench 8 sizes (8×10mm—22×24mm)
- VRL Ratchet Handle 2 type (□9.5mm, □12.7mm)

# Identify the wrench to a particular size by color

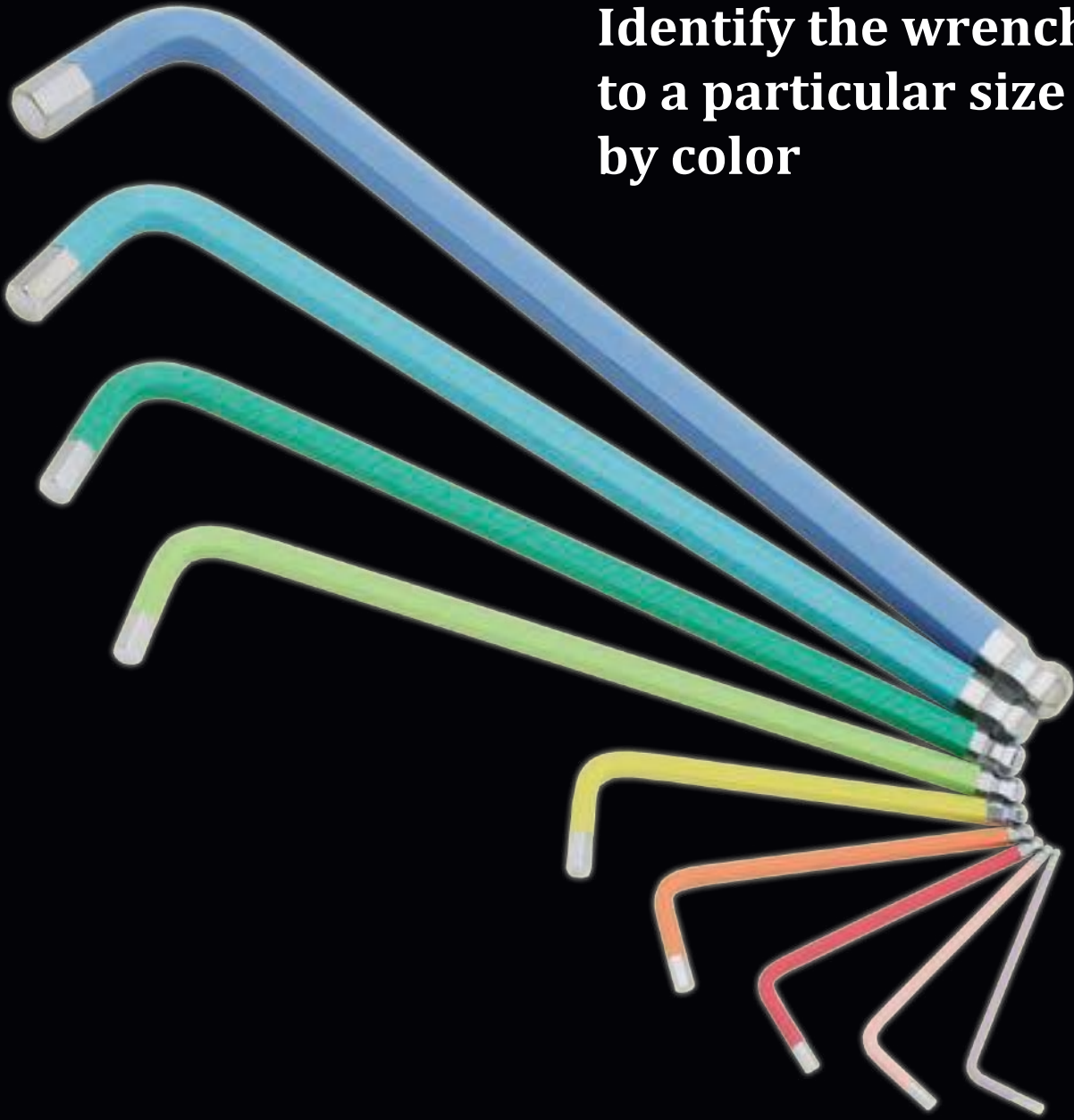

## Different Colors For Each Size

Painted with different colors to recognize the sizes without checking measurement labels on the hex keys.

Baked finish with excellent durability

Original color for high visibility

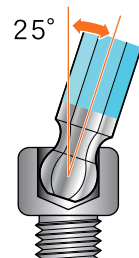
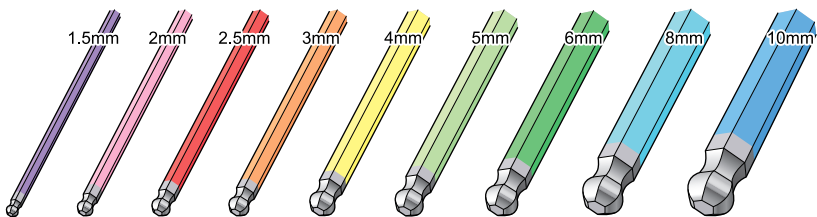

# Suitable for Working in Confined Spaces



## Double-Ended Hex Keys

This product only requires only 30 degrees turning angle (half of normal space), as both ends are bent twisted 90 degrees opposite angle. Please use the both end interchangeably to work continuously.

(DY/DZ)

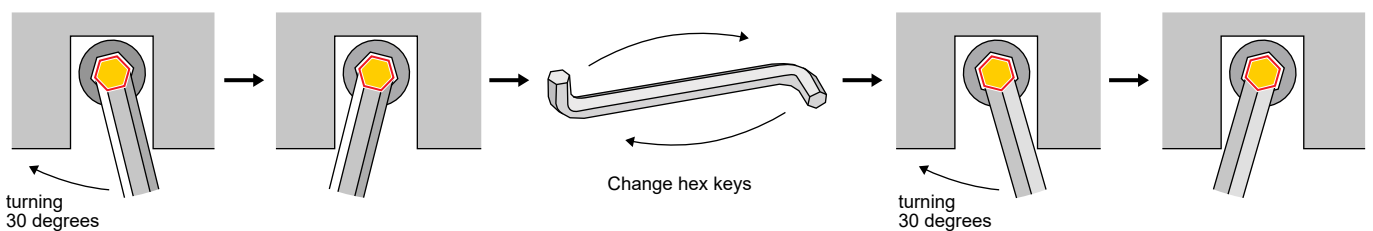
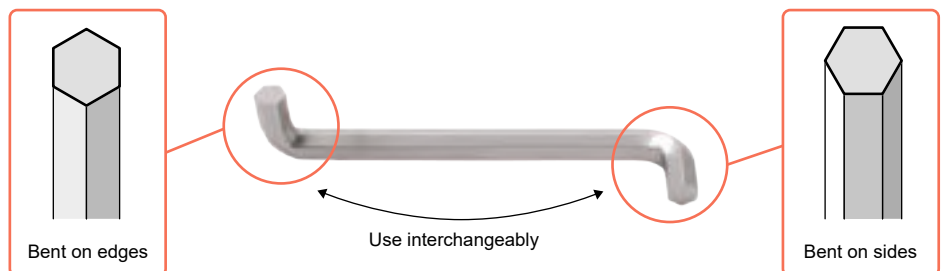



## Anti-Drop Hex Keys



### Catcherball

A spring suspension and a steel ball implanted by a high-precision processing technology holds the bolt securely. The bolt is firmly secured and does not need to be held by a hand before or after tightening, or during work in an inaccessible place.

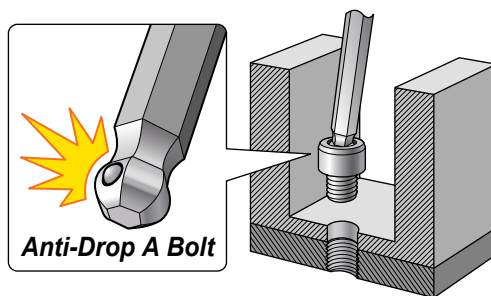

**Anti-Drop A Bolt**



# The Definitive Collection of Plumbing Tools

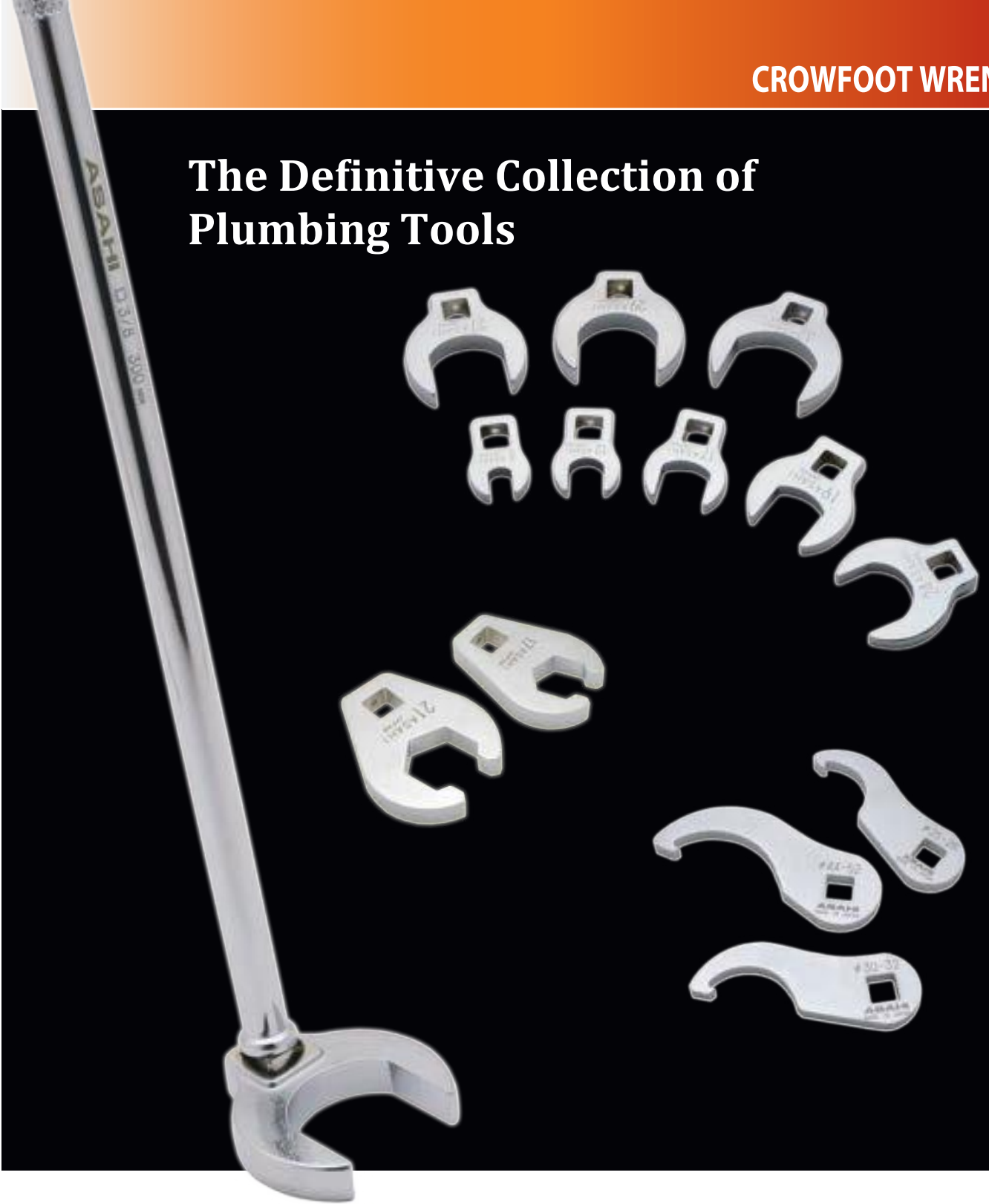

## Spanner Type / Flare Nut Type

- Air conditioner
- Around power steering
- Hydraulic piping for brakes
- Around various sensors
- Maintenance of hydraulic piping
- Other various piping

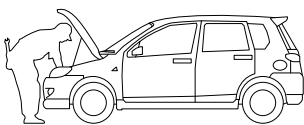

For automobile maintenance

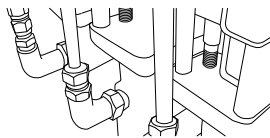

For machine maintenance

## Hook Spanner Type

- For motorcycle suspension and steering adjustment
- Around Installation and torque management of bearing nuts

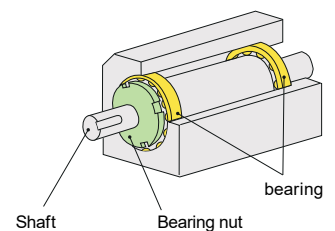
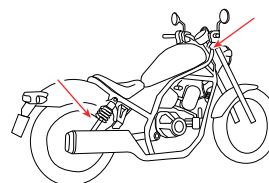

**New item**

**AQKU Long Ball Point Hexagon Key Wrench With Holding Ball Type**

**Auroline®**

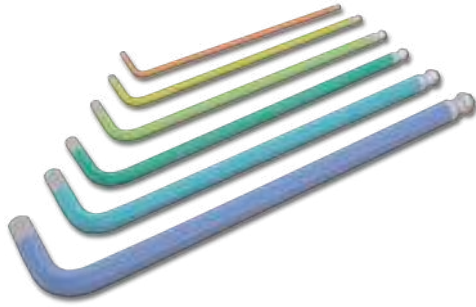

Code	⌀ mm	L mm	ℓ mm	Weight g		Price ¥
AQKU030	3	126	20	8.8	-	950
AQKU040	4	142	23	16	-	1,020
AQKU050	5	160	28	30	-	1,210
AQKU060	6	180	32	50	-	1,590
AQKU080	8	200	36	100	-	2,020
AQKU100	10	224	40	178	-	2,770

- Special Alloy Steel ( ~ 060 )
- Alloy Steel (080 ~ )
- Nickel Chrome Plating
- Baking Finish

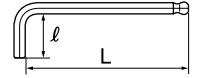

**Auroline®**



9Pcs.		1.5 mm	2 mm	2.5 mm	3 mm	4 mm	5 mm	6 mm	8 mm	10 mm
		without Catcher Ball			with Catcher Ball					

Code	⌀ mm	Weight g		Price ¥
AQKUS91	AQKU-1.5, 2, 2.5 AQKU-3, 4, 5, 6, 8, 10	420	5	12,400

- Plastic Holder
- Blister pack 290 × 90 × 25mm

**VC 6 Crowfoot Wrench, Spanner Type**

**19.0 mm**



Code	⌀ mm	B mm	b mm	H mm	L mm	effective length ℓ mm	Weight g	Price ¥
VC6030	30	55	36	19	89	55	380	11,100
VC6032	32	60	36	19	90	55	410	11,600
VC6036	36	66	38	19	93	55	450	13,000
VC6041	41	74	38	19	106	65	560	14,400
VC6046	46	82	42	19	110	65	650	16,300
VC6050	50	90	42	19	113	65	720	17,300
VC6055	55	96	45	19	117	65	780	18,200

- Nickel Chrome Plating

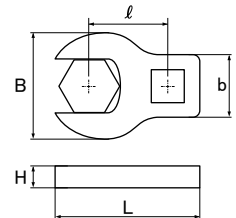

### VCK Crowfoot Wrench, Hook Spanner Type

Code	mm	C mm	T mm	H mm	L mm	effective length ℓ mm	Weight g	Price ¥
VCK3025	25~28	3	6	34	74	45	50	2,200
VCK3030	30~32	3	6	37	76	45	53	2,200
VCK3034	34~38	3.5	6	40	79	45	59	2,300
VCK3040	40~42	3.5	6	44	82	45	63	2,300
VCK3044	44~52	4	6	47	84	45	67	2,300
VCK3050	50~55	4.5	6	54	87	45	75	2,400
VCK3058	58~65	5	6	58	90	45	81	2,500

9.5 mm



Hand Tool



• Nickel Chrome Plating

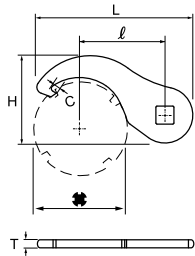

【For use with torque wrench】

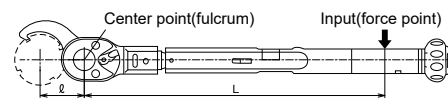

Torque conversion formula :

$$\frac{L}{(L + \ell)} \times \text{required torque value} = \text{input torque value}$$

EX)When using a torque wrench with an effective length of 190 mm and VCK3058 to tighten an object at 8 N·m.

L (Effective length of torque wrench) : 190mm  
 ℓ (Effective length of hook crowfoot wrench) : 45mm  
 Required torque value : 8N·m

$$\text{Torque conversion formula : } \frac{190}{(190+45)} \times 8 \approx 6.5$$

→When the torque wrench is set to 6.5N·m, the torque can be tightened with 8N·m

### VCF Crowfoot Wrench, Flare Nut Type

Code	mm	D mm	T mm	L mm	effective length ℓ mm	Weight g	Price ¥
VCF3008	8	18.3	8	46	30	36	2,300
VCF3010	10	22.0	8	48	30	41	2,400
VCF3012	12	25.5	8	48	30	45	2,400
VCF3014	14	30.0	8	50	30	52	2,550
VCF3017	17	35.5	8	54	30	65	2,640
VCF3019	19	40.0	8	56	30	76	2,730
VCF3022	22	43.5	8	58	30	83	2,790

9.5 mm



Hand Tool



• Nickel Chrome Plating

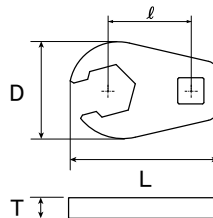

### SST Single Open End Spanner

Code	mm	C mm	T <sub>1</sub> mm	T <sub>2</sub> mm	L mm	Weight g	Price ¥
SST0008	8	19.5	4	3	85	23.5	1,040
SST0010	10	22	4.7	3	104	36.5	1,100
SST0012	12	25.5	5.5	3	109	44	1,120
SST0013	13	26.8	6.2	3.5	117.5	46	1,600
SST0014	14	30.8	6.2	3.8	145	69	1,620
SST0017	17	37	7.7	4	168.6	121	1,950
SST0021	21	45	8.5	4	209.7	187	2,650
SST0024	24	49.5	10	4.5	245.7	258	3,200

• Nickel Chrome Plating

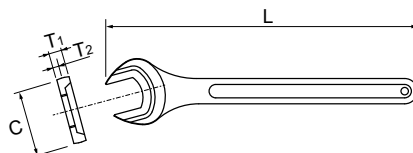

**New item**

## RS Ring Spanner

Three product sizes added



Code	mm	D mm	T mm	L mm	Weight g	Box	Price ¥
RS0015	15	25.5	11	195	105	10	1,130
RS0016	16	25.5	11	195	105	10	1,130
RS0018	18	30	12.5	215	160	10	1,050

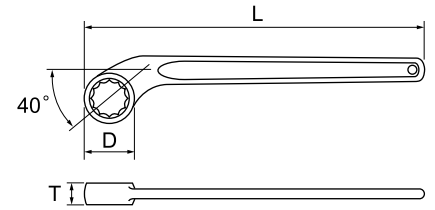

## CP Combination Wrench

Coming soon



CPS0710

**7Pcs.**

Code **CPS0710**

Price **¥10,400**

Set Contains

Combination Wrench CP-8, 10, 12, 13, 14, 17, 19

- Weight 750g
- Tool Roll 295 × 273mm

## SNT Thin Spanner

One product sizes added



Code	mm	C <sub>1</sub> mm	C <sub>2</sub> mm	T mm	L mm	Weight g	Box	Price ¥
SNT1415	14×15	30	33	4	148	60	10	620

- Nickel Chrome Plating

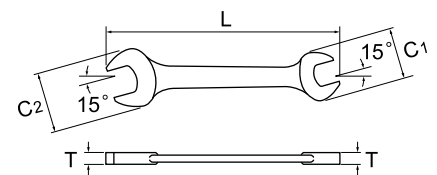



### LCW Combination Wrench

Code	mm	C mm	D mm	T <sub>1</sub> mm	T <sub>2</sub> mm	L mm	Weight g		Price ¥
LCW006	6	13.0	10.5	2.9	5.0	100	11	10	1,130
LCW009	9	21.5	15.3	4.2	6.5	119	22	10	1,130
LCW011	11	24.0	17.5	5.0	7.0	135	30	10	1,380
LCW018	18	40.0	28.5	7.0	11.5	235	134	10	2,160

• Nickel Chrome Plating

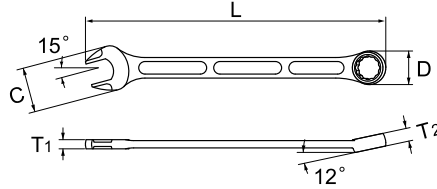

Four product sizes added



### LCWU Combination Wrench

Code	mm	C mm	D mm	T <sub>1</sub> mm	T <sub>2</sub> mm	L mm	Weight g		Price ¥
LCWU015	15	34.5	23.7	6.0	8.5	105	60	-	1,800
LCWU016	16	34.5	23.7	6.0	8.5	105	61	-	1,800

• Nickel Chrome Plating

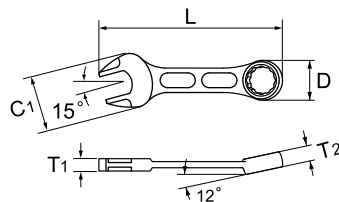

Two product sizes added



### SL Double Open End Spanner

Code	mm	C <sub>1</sub> mm	C <sub>2</sub> mm	T mm	L mm	Weight g		Price ¥
SL1315	13×15	28.0	32.5	6.5	157	83	10	1,260
SL1618	16×18	34.5	38.0	6.8	178	122	10	1,490

• Nickel Chrome Plating

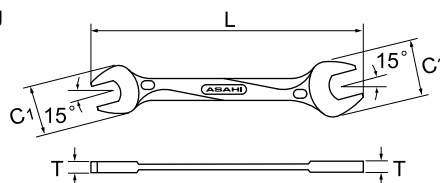

Two product sizes added



# Tool Set

## LIGHTTOOL model

TS3100

1/2"  
Drive45  
pcs.

Double Open End Spanner  
Offset Wrench  
Ratchet Handle

**LIGHTTOOL®**

Hexagon Key Wrench

**DX2000TOOLS**  
Catcher Ball / Long / Ball Point type

Tool Box

Metallic

## Revowave model

TS3200

1/2"  
Drive44  
pcs.

Double Open End Spanner  
Offset Wrench  
Ratchet Handle

**Revowave®**

Hexagon Key Wrench

**DX2000TOOLS**  
Catcher Ball / Long / Ball Point

Socket

Hybrid Socket

Tool Box

Metallic

## Compact Case model

TS4100

1/2"  
Drive36  
pcs.

Combination Wrench

**Revowave®**

Ratchet Handle

**LIGHTTOOL®**

Hexagon Key Wrench

**DX2000TOOLS**  
Long / Ball Point type

Tool Box

Metallic

## Double Open End Spanner / Offset Wrench model

TS2000

1/2"  
Drive48  
pcs.

Ratchet Handle

**LIGHTTOOL®**

Tool Box

Plastic

## Combination Wrench model

TS2100

1/2"  
Drive46  
pcs.

Ratchet Handle

**LIGHTTOOL®**

Tool Box

Plastic





# LIGHTOOL model

## TS3100 Tool Set

**45Pcs.**

Code **TS3100** Price **¥106,600**

**1/2" Drive**

Set Contains	
Double Open End Spanner <b>LIGHTOOL®</b>	LSX-5.5×7, 8×10, 11×13, 12×14, 17×19, 22×24 
Offset Wrench <b>LIGHTOOL®</b>	LOF-10×12, 11×13, 14×17, 19×21, 22×24 
Ratchet Handle <b>LIGHTOOL®</b>	LVR4252
Socket (12point)	VS4-17, 19, 21, 22, 24, 26, 27
Socket (6point)	VJR4-10, 12, 13, 14
Extension Bar	VE0415 (150mm)
Long Ball Point Hexagon Key Wrench Set, With Holding Ball Type (9pcs.)	AQKS910 (AQ- 1.5, 2, 2.5 AQK- 3, 4, 5, 6, 8, 10)
Go-Through Screwdriver (Soft Grip)	SUN FLAG No.888 ⊕No.1×75mm ⊖5.5×75mm ⊕No.2×100mm ⊖6.0×100mm ⊕No.3×150mm ⊖8.0×150mm
Adjustable Wrench	Pro-Auto (300mm)
Combination Plier	PP0200 
Water Pump Plier	PPW0250 
Side Cutting Plier	KEIBA PV-107
Diagonal Cutting Plier	KEIBA N-206
Combination Hammer	OH CH-10 (1pound)

- Weight 11.7kg
- Tool Box 220×415×310mm



### LIGHTOOL - Super Lightweight tools

Highly portable and workable tools are suitable for work in high places or for long periods of use.

It is 20% lighter on the average than our conventional products.

### Catcher Ball - Anti-Drop Hex Keys

A spring suspension and a steel ball implanted by a high-precision processing technology holds the bolt securely.

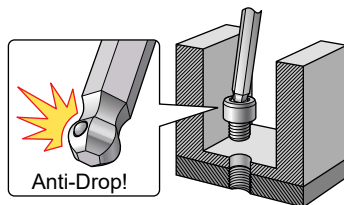

### Metallic tray

The metallic trays are designed to be easy to take tools in and out. Also, they are much more durable than plastic trays and suitable for any types of workplace. Matte-black paint trays go well together with a silver-colored tool case.



TOOL SETS

SPANNERS

STRIKING FACE WRENCHES

HOOK SPANNERS

DX2000 TOOLS  
HEXAGON KEY WRENCHES

HEXAGON KEY WRENCHES

TORQUE WRENCHES

CROWFOOT WRENCHES

SOCKETS

OTHER TOOLS

# Revowave model

## TS3200 Tool Set

<b>44Pcs.</b>	Code	<b>TS3200</b>	Price	<b>¥106,100</b>
Set Contains				
Double Open End Spanner <b>Revowave®</b>	SL-5.5×7, 8×10, 11×13, 12×14, 17×19, 22×24	JIS JGA		
Offset Wrench <b>Revowave®</b>	OL-10×12, 11×13, 14×17, 19×21, 22×24	JIS JGA		
Ratchet Handle <b>Revowave®</b>	VRL4250			
Socket (Hybrid Type)	VF4- 10, 12, 13, 14, 15, 17, 19, 21, 22, 24			
Extension Bar	VE0415 (150mm)			
Long Ball Point Hexagon Key Wrench Set, With Holding Ball Type (9pcs.)	AQKS910 (AQ- 1.5, 2, 2.5 AQK- 3, 4, 5, 6, 8, 10)			
Go-Through Screwdriver (Soft Grip)	SUN FLAG No.888 ⊕No.1×75mm ⊖5.5×75mm ⊕No.2×100mm ⊖6.0×100mm ⊕No.3×150mm ⊖8.0×150mm			
Adjustable Wrench	Pro-Auto (250mm)			
Combination Plier	PP0200	JIS JGA		
Water Pump Plier	PPW0250	JIS JGA		
Side Cutting Plier	KEIBA PV-107			
Diagonal Cutting Plier	KEIBA N-206			
Combination Hammer	OH CH-10 (1pound)			

- Weight 11.5kg
- Tool Box 220 × 415 × 310mm

### Revowave - High Workability

The curved surface of the neck fits well into hands and increases comfort when working.

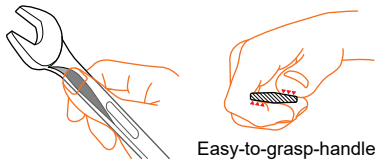

### Catcher Ball - Anti-Drop Hex Keys

A spring suspension and a steel ball implanted by a high-precision processing technology holds the bolt securely.

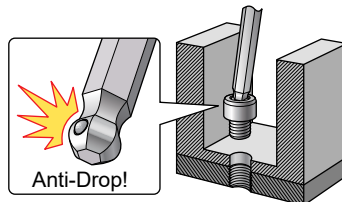

### Hybrid Socket

Due to the unique spline shape interior, a socket is compatible with metric or inch-sized bolts, hexalobe screws, and square bolts.

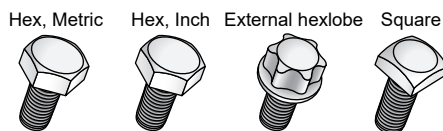

### Metallic tray

The metallic trays are designed to be easy to take tools in and out. Also, they are much more durable than plastic trays and suitable for any types of workplace. Matte-black paint trays go well together with a silver-colored tool case.



TOOL SETS

SPANNERS

STRIKING FACE WRENCHES

HOOK SPANNERS

DX2000 TOOLS  
HEXAGON KEY WRENCHES

HEXAGON KEY WRENCHES

TORQUE WRENCHES

CROWFOOT WRENCHES

SOCKETS

OTHER TOOLS





## Compact Case model

### TS4100 Tool Set

**36Pcs.**

Code **TS4100** Price **¥75,300**

**1/2"**  
Drive

Set Contains	
Combination Wrench <b>Revowave</b>	CL- 8, 10, 12, 13, 14, 17, 19, 22, 24 
Long Ball Point Hexagon Key Wrench Set (8pcs.)	AQS0880 (AQ- 1.5, 2, 2.5, 3, 4, 5, 6, 8)
Socket (6point)	VJR4- 10, 12, 13, 14
Socket (12point)	VS4- 17, 19, 21, 22, 24
Ratchet Handle <b>LIGHTOOL</b>	LVR4252
Extension Bar	VE0415 (150mm)
Go-Through Screwdriver (Soft Grip)	SUN FLAG No.888 ⊕ No.1 × 75mm ⊖ 5.5 × 75mm ⊕ No.2 × 100mm ⊖ 6.0 × 100mm
Adjustable Wrench	Pro-Auto (300mm)
Combination Plier	PP0200 
Side Cutting Plier	CP-175 
Ball Pin Hammer	HP0450 (1pound)

- Weight 9kg
- Tool Box 230 × 395 × 120mm



### Revowave - Combination Wrench

The curved surface of the neck fits well into hands and increases comfort when working.

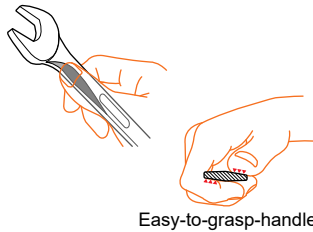
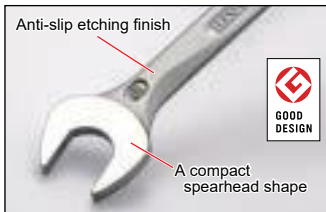

Easy-to-grasp-handle

### LIGHTOOL - Super Lightweight tools

Highly portable and workable tools are suitable for work in high places or for long periods of use.



### Tool Case

As the upper part of the tool case is sliding type, opening and closing can be done easily. It is 120 mm high and compact so it does not take up space when storing and it is convenient to carry.



### Tray for sockets

The metallic trays are designed to be easy to take tools in and out. A tray can store different sizes of sockets, ratchet handles, and extension bars. It is useful for carrying sockets and ratchets to work areas.











## Double Open End Spanner / Offset Wrench model

### TS2000 Tool Set

**48Pcs.**

Code **TS2000** Price **¥ 84,300**

**1/2"**  
Drive

Set Contains	
Double Open End Spanner	SMS0622 (SM- 5.5 × 7, 8 × 10, 11 × 13, 12 × 14, 17 × 19, 22 × 24) 
Offset Wrench	8 × 10, 11 × 13, 12 × 14, 14 × 17, 17 × 19, 22 × 24 
Hexagon Key Wrench Set (8pcs.)	AWS0820 (AW- 3, 4, 5, 6, 8, 10, 12, 14)
Socket (12point)	VS4- 10, 11, 12, 13, 14, 17, 19, 21, 22, 24
Plug Socket (12point)	VP0421 (21mm)
Ratchet Handle <b>LIGHTOOL®</b>	LVR4252
Extension Bar	VE0415 (150mm)
Universal Joint	VU0400
Spinner Handle	VH0430 (300mm)
Cross Bar	VB0425 (250mm)
Go-Through Screwdriver (Plastic Grip)	⊕ No.1 × 75mm    ⊖ 5.5 × 75mm ⊕ No.2 × 100mm    ⊖ 6.0 × 100mm ⊕ No.3 × 150mm
Stubby Screwdriver (Plastic Grip)	Interchangeable (Phillips & Slotted)
Adjustable Wrench	Pro-Auto (250mm)
Combination Plier	PP0200 
Side Cutting Plier	CP-175 
Diagonal Cutting Plier	CN-160 
Needle Nose Plier	RP-150 
Ball Pin Hammer	HP0450 (1pound)

- Weight 9.3kg
- Tool Box 260 × 445 × 222mm

### A Wide Range of Sizes and Shapes

Mainly we have a rich variety of frequently used tools centering on double open spanner and double offset wrench.

### Tool Case

It is light and convenient to carry and abs plastic tool case. The upper tray can store the tool properly, it can be removed and carried. The lower space is large capacity and can be store many hand tools.



TOOL SETS

SPANNERS

STRIKING FACE WRENCHES

HOOK SPANNERS

DX2000 TOOLS  
HEXAGON KEY WRENCHES

HEXAGON KEY WRENCHES

TORQUE WRENCHES

CROWFOOT WRENCHES

SOCKETS

OTHER TOOLS





## Combination Wrench model

### TS2100 Tool Set

**46Pcs.**

Code **TS2100** Price **¥84,300**

**1/2"**  
Drive

Set Contains	
Combination Wrench	CP- 5.5, 7, 8, 10, 12, 13, 14, 17, 19, 22, 24 
Hexagon Key Wrench Set (9pcs.)	AWS0990 (AW- 1.5, 2, 2.5, 3, 4, 5, 6, 8, 10)
Socket (12point)	VS4- 10, 12, 13, 14, 17, 19, 21, 22, 24
Ratchet Handle <b>LIGHTOOL®</b>	LVR4252
Extension Bar	VE0415 (150mm)
Universal Joint	VU0400
Spinner Handle	VH0430 (300mm)
Cross Bar	VB0425 (250mm)
Go-Through Screwdriver (Plastic Grip)	⊕ No.1 × 75mm    ⊖ 5.5 × 75mm ⊕ No.2 × 100mm    ⊖ 6.0 × 100mm ⊕ No.3 × 150mm
Stubby Screwdriver (Plastic Grip)	Interchangeable (Phillips & Slotted)
Adjustable Wrench	Pro-Auto (250mm)
Combination Plier	PP0200 
Side Cutting Plier	CP-175 
Diagonal Cutting Plier	CN-160 
Needle Nose Plier	RP-150 
Ball Pin Hammer	HP0450 (1 pound)

- Weight 8kg
- Tool Box 260 × 445 × 222mm



TOOL SETS

SPANNERS

STRIKINGFACE WRENCHES

HOOK SPANNERS

DX2000 TOOLS  
HEXAGON KEY WRENCHES

HEXAGON KEY WRENCHES

TORQUE WRENCHES

CRIMPFOOT WRENCHES

SOCKETS

OTHER TOOLS

### A Wide Range of Sizes and Shapes





Mainly we have a rich variety of frequently used tools centering on combination wrench.







### Tool Case

It is light and convenient to carry and abs plastic tool case. The upper tray can store the tool properly, it can be removed and carried. The lower space is large capacity and can be store many hand tools.



# Spanners

Single Open End Spanner			
	SS	SSP	SST
Heavy Duty	●	●	
Thin Type			●
 Width across flat			
5.5	●	●	
6	●	●	
7	●	●	
8	●	●	●
9	●	●	
10	●	●	●
11	●	●	
12	●	●	●
13	●	●	●
14	●	●	●
16	●	●	
17	●	●	●
18	●	●	
19	●	●	
21	●	●	●
22	●	●	
23	●	●	
24	●	●	●
26	●	●	
27	●	●	
29	●	●	
30	●	●	
32	●	●	
35	●	●	
36	●	●	
38	●	●	
41	●	●	
46	●	●	
50	●	●	
54	●	●	
55	●	●	
58	●	●	
60	●	●	
63	●	●	
65	●	●	
67	●	●	
70	●	●	
71	●	●	
75	●	●	
77	●	●	
80	●	●	
85	●	●	
90	●	●	
95	●	●	
100	●	●	
105	●	●	
110	●	●	
115	●	●	
120	●	●	
125	●	●	
130	●	●	
135	●	●	
140	●	●	
145	●	●	
150	●	●	
155	●	●	
160	●	●	
165	●	●	
170	●	●	
175	●	●	
180	●	●	
185	●	●	
190	●	●	
195	●	●	
200	●	●	

Double Open End Spanner						
	SW	SL	LSX	SNT	SMC	SM
Heavy Duty	●					
Thin Type				●		
LIGHT TOOL			●			
Revovave		●				
 Width across flat						
3.2 × 4					●	
4 × 5					●	
5.5 × 7	●	●	●		●	●
6 × 7	●	●	●			●
6 × 8	●					
7 × 8	●					●
8 × 9	●	●		●		●
8 × 10	●	●	●			●
9 × 10	●					
10 × 12	●	●	●	●		●
10 × 13	●	●				●
10 × 14	●					
11 × 13	●	●	●	●		●
12 × 14	●	●	●			●
13 × 15		●	●			
13 × 17	●	●	●			●
14 × 15				●		
14 × 17	●	●	●	●		●
16 × 18		●	●			
17 × 19	●	●	●			●
17 × 21	●					
19 × 21	●	●	●	●		●
19 × 22	●					
19 × 24	●					
21 × 23	●					●
21 × 26	●					
22 × 23				●		
22 × 24	●	●	●			●
23 × 26	●					
24 × 27	●			●		
24 × 30	●					
26 × 29	●					
26 × 32	●					
27 × 30	●					
29 × 32	●					
30 × 32	●			●		
32 × 35	●					
32 × 36	●					
35 × 41	●					
36 × 41	●					
41 × 46	●					
41 × 50	●					
46 × 50	●					
50 × 54	●					
50 × 55	●					
50 × 58	●					
50 × 60	●					
54 × 58	●					
55 × 60	●					

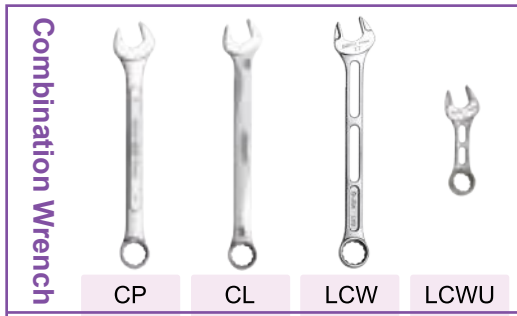

Combination Wrench	CP	CL	LCW	LCWU
LIGHT TOOL			●	●
Revolve		●		
mm Width across flat				
5.5	●	●	●	●
6	●	●	●	●
7	●	●	●	●
8	●	●	●	●
9	●	●	●	●
10	●	●	●	●
11	●	●	●	●
12	●	●	●	●
13	●	●	●	●
14	●	●	●	●
15	●	●	●	●
16	●	●	●	●
17	●	●	●	●
18	●	●	●	●
19	●	●	●	●
20	●	●	●	●
21	●	●	●	●
22	●	●	●	●
23	●	●	●	●
24	●	●	●	●
25	●	●	●	●
26	●	●	●	●
27	●	●	●	●
28	●	●	●	●
29	●	●	●	●
30	●	●	●	●
31	●	●	●	●
32	●	●	●	●
35	●	●	●	●
36	●	●	●	●
38	●	●	●	●
41	●	●	●	●
46	●	●	●	●
50	●	●	●	●
54	●	●	●	●
55	●	●	●	●
58	●	●	●	●
60	●	●	●	●

**Inch**  
CPX

mm Width across flat	
1/4	●
5/16	●
3/8	●
7/16	●
1/2	●
9/16	●
5/8	●
11/16	●
3/4	●
13/16	●
7/8	●
15/16	●
1	●
1-1/16	●
1-1/8	●
1-1/4	●



Ring Spanner	RS	RD
Deep Type		●
mm Width across flat		
10	●	
11	●	
12	●	
13	●	
14	●	
15	●	
16	●	
17	●	●
18	●	
19	●	●
21	●	●
22	●	●
23	●	
24	●	●
26	●	
27	●	
29	●	
30	●	
32	●	
35	●	
36	●	
38	●	
41	●	
46	●	
50	●	
54	●	
55	●	
58	●	
60	●	
63	●	
65	●	
67	●	
70	●	
71	●	
75	●	
77	●	
80	●	
85	●	
90	●	
95	●	
100	●	
105	●	
110	●	
115	●	
120	●	
125	●	
130	●	
135	●	
140	●	
145	●	
150	●	
155	●	
160	●	
165	●	
170	●	
175	●	
180	●	
185	●	
190	●	
195	●	
200	●	

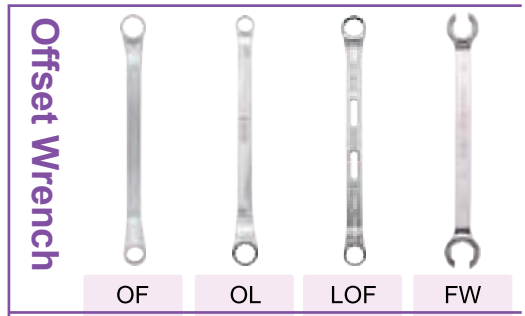

Offset Wrench	OF	OL	LOF	FW
LIGHT TOOL			●	
Revolve		●		
Flare Nut				●
mm Width across flat				
8 × 9	●			
8 × 10	●	●	●	●
10 × 11	●			●
10 × 12	●	●	●	●
10 × 13	●			
11 × 13	●	●	●	●
12 × 14	●	●	●	●
13 × 15	●		●	
13 × 17	●			
14 × 17	●	●	●	●
16 × 18	●		●	
17 × 19	●	●	●	
17 × 21	●			
19 × 21	●	●	●	●
19 × 22	●			
19 × 24	●			
21 × 23	●			
21 × 26	●			
22 × 24	●	●	●	
23 × 26	●			
24 × 27	●			
24 × 30	●			
26 × 29	●			
26 × 32	●			
27 × 30	●			
29 × 32	●			
30 × 32	●			
32 × 35	●			
32 × 36	●			
35 × 41	●			
36 × 41	●			

# SS Single Open End Spanner, Metric



Thicker bolt contact surfaces enable work at higher loads—it's over 1.5 times stronger than our SN spanner.

The handle is designed for easy gripping, and the surface is finished in cationic electrodeposition coating for outstanding rust prevention.

This is a strong tool that can be used in harsh environments with peace of mind.

Code	mm	C <sub>1</sub> mm	T mm	L mm	Weight g		Price ¥
SS0105	105	215	35	825	12,400	-	92,900
SS0110	110	215	35	825	12,600	-	99,200
SS0115	115	235	38	870	15,200	-	110,900
SS0120	120	235	38	870	14,600	-	122,800
SS0125	125	250	40	900	-	-	-
SS0130	130	250	40	900	-	-	-
SS0135	135	270	40	925	-	-	-
SS0140	140	270	40	925	-	-	-
SS0145	145	290	45	950	-	-	-
SS0150	150	290	45	950	-	-	-
SS0155	155	310	45	975	-	-	-
SS0160	160	310	45	975	-	-	-
SS0165	165	330	50	1,000	-	-	-
SS0170	170	330	50	1,000	-	-	-
SS0175	175	350	50	1,025	-	-	-
SS0180	180	350	50	1,025	-	-	-
SS0185	185	370	55	1,050	-	-	-
SS0190	190	370	55	1,050	-	-	-
SS0195	195	390	55	1,075	-	-	-
SS0200	200	390	55	1,075	-	-	-

- Cathodic Electrodeposition
- Special Order (0125 ~ )
- Heavy Duty

H **JIS JQA** ( ~ SS0080)

Code	mm	C mm	T mm	L mm	Weight g		Price ¥
SS0005	5.5	17	3.2	82	10	10	680
SS0006	6	17	3.2	82	10	10	680
SS0007	7	20	4	92	18	10	680
SS0008	8	20	4	92	18	10	680
SS0009	9	24	4.5	105	25	10	850
SS0010	10	24	4.5	105	25	10	700
SS0011	11	29	5.5	122	35	10	850
SS0012	12	29	5.5	122	35	10	750
SS0013	13	33	6.2	135	43	10	750
SS0014	14	33	6.2	135	42	10	800
SS0016	16	39	7.7	165	82	10	1,050
SS0017	17	39	7.7	165	95	10	850
SS0018	18	43	8.2	177	120	10	1,090
SS0019	19	43	8.2	177	115	10	930
SS0021	21	49	9.5	200	168	10	1,090
SS0022	22	49	9.5	200	165	10	1,240
SS0023	23	53	10.5	220	230	10	1,600
SS0024	24	53	10.5	220	227	10	1,430
SS0026	26	59	11.5	245	315	10	1,500
SS0027	27	59	11.5	245	293	10	1,650
SS0029	29	66	12.5	275	444	10	2,200
SS0030	30	68	12.5	275	438	10	1,940
SS0032	32	68	12.5	275	440	10	2,100
SS0035	35	80	14.5	315	665	5	3,150
SS0036	36	80	14.5	315	588	5	3,100
SS0038	38	80	14.5	315	648	5	4,110
SS0041	41	90	16	360	870	5	3,890
SS0046	46	102	18.5	410	1,290	5	5,400
SS0050	50	102	18.5	410	1,260	5	6,800
SS0054	54	117	20	470	1,850	2	12,400
SS0055	55	117	20	470	1,830	2	11,300
SS0058	58	117	20	470	1,800	2	15,200
SS0060	60	130	22	530	2,550	2	17,600
SS0063	63	130	22	530	2,480	2	20,600
SS0065	65	130	22	530	2,480	2	22,900
SS0067	67	143	24	575	3,200	2	26,300
SS0070	70	143	24	575	3,160	2	30,800
SS0071	71	143	24	575	3,160	2	32,100
SS0075	75	161	24	645	3,950	2	35,500
SS0077	77	161	24	645	3,950	2	43,800
SS0080	80	161	24	645	3,900	2	43,800
SS0085	85	178	29	715	7,500	-	47,700
SS0090	90	178	29	715	7,500	-	56,200
SS0095	95	195	32	770	9,900	-	59,400
SS0100	100	195	32	770	9,700	-	73,700

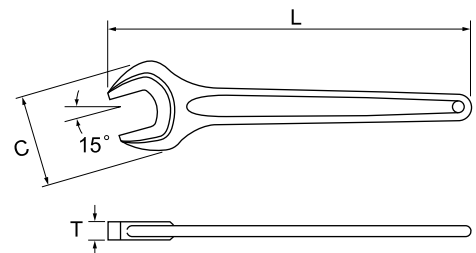



## SSP Single Open End Spanner, Metric

Code	mm	C mm	T mm	L mm	Weight g	Box	Price ¥
SSP0005	5.5	17	3.2	82	10	10	750
SSP0006	6	17	3.2	82	10	10	750
SSP0007	7	20	4	92	18	10	750
SSP0008	8	20	4	92	18	10	750
SSP0009	9	24	4.5	105	25	10	850
SSP0010	10	24	4.5	105	25	10	810
SSP0011	11	29	5.5	122	35	10	850
SSP0012	12	29	5.5	122	35	10	820
SSP0013	13	33	6.2	135	43	10	820
SSP0014	14	33	6.2	135	42	10	860
SSP0017	17	39	7.7	165	95	10	940
SSP0019	19	43	8.2	177	115	10	1,010
SSP0021	21	49	9.5	200	168	10	1,220
SSP0022	22	49	9.5	200	165	10	1,400
SSP0023	23	53	10.5	220	230	10	1,710
SSP0024	24	53	10.5	220	227	10	1,640
SSP0026	26	59	11.5	245	315	10	1,670
SSP0027	27	59	11.5	245	293	10	1,830
SSP0029	29	66	12.5	275	444	10	2,370
SSP0030	30	68	12.5	275	438	10	2,260
SSP0032	32	68	12.5	275	440	10	2,390
SSP0035	35	80	14.5	315	665	5	3,600
SSP0036	36	80	14.5	315	588	5	3,530
SSP0038	38	80	14.5	315	648	5	4,680
SSP0041	41	90	16	360	870	5	4,380
SSP0046	46	102	18.5	410	1,290	5	5,800
SSP0050	50	102	18.5	410	1,260	5	7,500
SSP0055	55	117	20	470	1,830	2	11,900
SSP0060	60	130	22	530	2,550	2	19,100
SSP0065	65	130	22	530	2,480	2	24,400
SSP0070	70	143	24	575	3,160	2	32,700
SSP0075	75	161	24	645	3,950	2	35,700

- Heavy Duty
- Nickel Chrome Plating

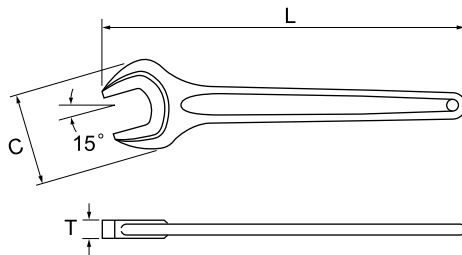

Thicker bolt contact surfaces enable work at higher loads—it's over 1.5 times stronger than our SN spanner.  
The surface is finished in nickel-chrome plating for an attractive finish.  
This is a strong tool that can be used in harsh environments with peace of mind.

## SST Thin Type Strong Spanner, Metric

**NEW**



Code	mm	C mm	T <sub>1</sub> mm	T <sub>2</sub> mm	L mm	Weight g	Price ¥
SST0008	8	19.5	4	3	85	23.5	1,040
SST0010	10	22	4.7	3	104	36.5	1,100
SST0012	12	25.5	5.5	3	109	44	1,120
SST0013	13	26.8	6.2	3.5	117.5	46	1,600
SST0014	14	30.8	6.2	3.8	145	69	1,620
SST0017	17	37	7.7	4	168.6	121	1,950
SST0021	21	45	8.5	4	209.7	187	2,650
SST0024	24	49.5	10	4.5	245.7	258	3,200

• Nickel Chrome Plating

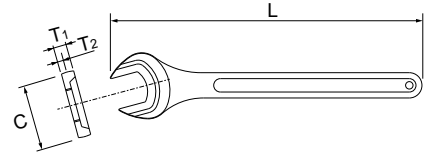

TOOL SETS

SPANNERS

STRIKING FACE WRENCHES

HOOK SPANNERS

DX2000 TOOLS  
HEXAGON KEY WRENCHES

HEXAGON KEY WRENCHES

TORQUE WRENCHES

CROWFOOT WRENCHES

SOCKETS

OTHER TOOLS

## SW Double Open End Spanner, Metric

Code	mm	C <sub>1</sub> mm	C <sub>2</sub> mm	T mm	L mm	Weight g		Price ¥
SW0507	5.5×7	16.5	19.5	3.7	100	22	10	740
SW0607	6×7	16.5	19.5	3.7	100	21	10	740
SW0608	6×8	17.5	21.5	4.2	105	25	10	740
SW0708	7×8	17.5	21.5	4.2	105	25	10	740
SW0809	8×9	21.5	23.5	4.2	115	32	10	830
SW0810	8×10	21.5	23.5	4.2	115	31	10	800
SW0910	9×10	21.5	23.5	4.2	115	30	10	870
SW1012	10×12	25.5	28.5	5.2	130	46	10	800
SW1013	10×13	25.5	32.5	6.2	140	55	10	810
SW1014	10×14	25.5	32.5	6.2	140	54	10	990
SW1113	11×13	29	33	6.2	140	56	10	830
SW1214	12×14	29	33	6.2	140	58	10	830
SW1317	13×17	33	39	7.7	165	109	10	850
SW1417	14×17	33	39	7.7	165	109	10	850
SW1719	17×19	39	43	8.2	177	149	10	980
SW1721	17×21	41	49	9.5	200	200	10	1,160
SW1921	19×21	41	49	9.5	200	193	10	1,210
SW1922	19×22	41	49	9.5	200	195	10	1,240
SW1924	19×24	44	55	10.5	220	267	10	1,400
SW2123	21×23	49	53	10.5	220	280	10	1,790
SW2126	21×26	50	59	11.5	230	337	10	1,490
SW2224	22×24	49	53	10.5	220	289	10	1,700
SW2326	23×26	50	59	11.5	230	332	10	1,960
SW2427	24×27	53	62	11.5	257	432	10	2,100
SW2430	24×30	53	62	11.5	257	418	10	2,130
SW2629	26×29	59	68	12.5	270	496	10	2,770
SW2632	26×32	59	68	12.5	270	499	10	2,430
SW2730	27×30	59	68	12.5	270	504	10	2,590
SW2932	29×32	65	72	13	280	573	10	3,650
SW3032	30×32	65	72	13	280	570	10	3,230
SW3235	32×35	72	79	14.5	310	766	5	3,920
SW3236	32×36	72	79	14.5	310	760	5	3,920
SW3541	35×41	79	90	16	350	1,126	5	4,670
SW3641	36×41	79	90	16	350	1,120	5	6,500
SW4146	41×46	90	101	18	410	1,530	2	8,400
SW4150	41×50	90	101	18	410	1,535	2	11,700
SW4650	46×50	101	109	19	430	1,920	2	11,100
SW5054	50×54	101	109	19	430	1,920	2	19,700
SW5055	50×55	101	109	19	430	1,830	2	17,100
SW5058	50×58	109	126	21	475	2,430	2	22,700
SW5060	50×60	109	126	21	475	2,230	2	22,700
SW5458	54×58	109	126	21	475	2,360	2	23,900
SW5560	55×60	109	126	21	475	2,320	2	23,900

- Cathodic Electrodeposition
- Heavy Duty

H  JGA (0507 ~ 2430, 2632 ~ 4600)

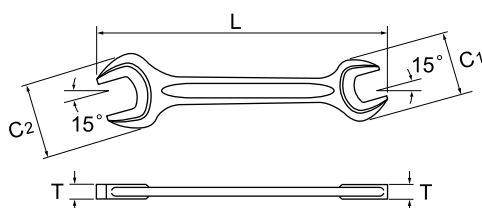

Thicker bolt contact surfaces enable work at higher loads—it's over 1.5 times stronger than our SN spanner.

The handle is designed for easy gripping, and the surface is finished in cationic electrodeposition coating for outstanding rust prevention.

This is a strong tool that can be used in harsh environments with peace of mind.

## SL Double Open End Spanner, Metric

**Revowave®**



Revowave features an innovative design, never seen before.  
The curved surface of its distinctive neck fits the worker's hand perfectly, providing excellent workability.

Code	mm	C <sub>1</sub> mm	C <sub>2</sub> mm	T mm	L mm	Weight g	Box	Price ¥
SL0507	5.5×7	12.7	15.5	2.9	102	12	10	770
SL0607	6×7	13.7	15.5	2.9	102	12	10	770
SL0809	8×9	17.5	19.5	4.0	111	25	10	800
SL0810	8×10	17.5	21.5	4.2	122	28	10	810
SL1012	10×12	21.5	25.5	5.2	133	43	10	840
SL1013	10×13	21.5	28.0	5.6	136	50	10	990
SL1113	11×13	23.5	28.0	6.0	138	56	10	1,100
SL1214	12×14	25.5	29.5	6.5	143	68	10	1,100
SL1315	13×15	28.0	32.5	6.5	157	83	10	1,260
SL1317	13×17	28.0	36.0	6.6	168	90	10	1,190
SL1417	14×17	29.5	36.0	6.7	170	100	10	1,230
SL1618	16×18	34.5	38.0	6.8	178	122	10	1,490
SL1719	17×19	36.0	40.0	7.0	185	130	10	1,490
SL1921	19×21	40.0	44.5	7.6	205	170	5	1,610
SL2224	22×24	46.5	50.5	8.5	225	240	5	2,030

• Decorative Chromium Plating

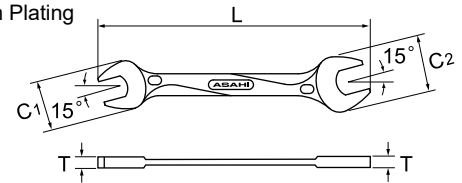

SLAS6

<b>6Pcs.</b>		Code	<b>SLAS6</b>	Price	<b>¥7,400</b>
Set Contains					
Double Open End Spanner	SL- 5.5×7, 8×10, 11×13, 12×14, 17×19, 22×24				

- Weight 560g
- Storage Box 125 × 240 × 50mm
- Plastic Holder (TFSLH01)



SLAS62

<b>6Pcs.</b>		Code	<b>SLAS62</b>	Price	<b>¥8,000</b>
Set Contains					
Double Open End Spanner	SL- 8×10, 11×13, 12×14, 14×17, 17×19, 22×24				

- Weight 650g
- Storage Box 125 × 240 × 50mm
- Plastic Holder (TFSLH01)



TFSLH01

Code	Weight g	Price ¥
TFSLH01	35	650

- for SLAS6 and SLAS62
- Plastic

## LSX Double Open End Spanner, Metric

Code	mm	C <sub>1</sub> mm	C <sub>2</sub> mm	T mm	L mm	Weight g		Price ¥
LSX0507	5.5×7	12.7	15.5	2.9	102	10	10	790
LSX0607	6×7	12.7	15.5	2.9	102	9	10	790
LSX0810	8×10	17.5	21.5	4.2	115	19	10	820
LSX1012	10×12	21.5	26.0	5.0	125	33	10	860
LSX1113	11×13	23.5	28.0	5.4	130	40	10	1,110
LSX1214	12×14	26.0	29.5	5.8	140	47	10	1,110
LSX1317	13×17	28.5	36.0	6.7	160	75	10	1,250
LSX1417	14×17	28.5	36.0	6.7	160	74	10	1,250
LSX1719	17×19	36.0	40.0	7.0	177	105	10	1,510
LSX1921	19×21	40.0	44.5	7.5	195	150	5	1,620
LSX2224	22×24	46.5	50.5	8.0	215	180	5	2,130

• Nickel Chrome Plating

S  

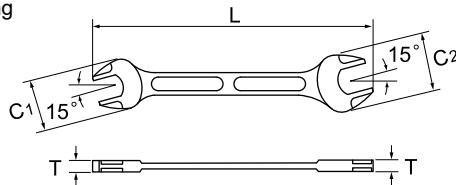

## LIGHTOOL®



LIGHTOOL is both portable and comfortable to use—an effective choice for working at high elevations or for long hours.

Achieved through painstaking testing, its optimized design and advanced forging technology ensure robust strength, which is the true hurdle of weight reduction, and its strength exceeds JIS standards.

**6Pcs.**

Code

**LSXS6**

Price

**¥7,400**

Set Contains

Double Open End Spanner LSX-5.5×7, 8×10, 11×13, 12×14, 17×19, 22×24

• Weight 505g

• Tool Roll 280×285mm



TOOL SETS

SPANNERS

STRIKING FACE WRENCHES

HOOK SPANNERS

DX2000 TOOLS  
HEXAGON KEY WRENCHES

HEXAGON KEY WRENCHES

TORQUE WRENCHES

CROWFOOT WRENCHES

SOCKETS

OTHER TOOLS



# SNT Thin Spanner



Suitable for use in places where ordinary spanners cannot fit, due to its significantly thinner profile.

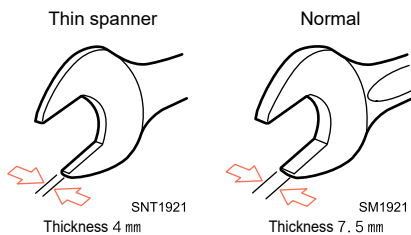

**NEW**

Code	mm	C <sub>1</sub> mm	C <sub>2</sub> mm	T mm	L mm	Weight g		Price ¥
SNT0809	8×9	19	21	3.2	106	20	10	510
SNT1012	10×12	23	26	3.2	126	30	10	510
SNT1113	11×13	26	30	4	136	50	10	570
SNT1415	14×15	30	33	4	148	60	10	620
SNT1417	14×17	30	33	4	148	60	10	620
SNT1921	19×21	40	45	4	192	100	10	930
SNT2223	22×23	43	49	4.5	205	110	10	1,240
SNT2427	24×27	50	56	4.5	235	182	10	1,570
SNT3032	30×32	63	66	4.5	275	244	10	2,560

• Nickel Chrome Plating

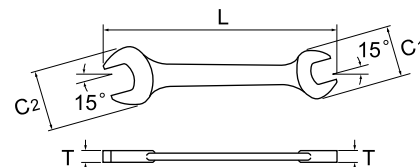

SNT0550

<b>5Pcs.</b>	Code	<b>SNT0550</b>	Price	<b>¥2,930</b>
--------------	------	----------------	-------	---------------

Set Contains	
Double Open End Spanner	SNT- 8×9, 10×12, 11×13, 14×17, 19×21

- Weight 290g
- Blister pack 270 × 70 × 30mm
- Metal Holder



SNT0800

<b>8Pcs.</b>	Code	<b>SNT0800</b>	Price	<b>¥8,700</b>
--------------	------	----------------	-------	---------------

Set Contains	
Double Open End Spanner	SNT- 8×9, 10×12, 11×13, 14×17, 19×21, 22×23, 24×27, 30×32

- Weight 850g
- Casing 306 × 65 × 36mm

TOOL SETS

SPANNERS

STRIKING FACE WRENCHES

HOOK SPANNERS

HEXAGON KEY WRENCHES

HEXAGON KEY WRENCHES

TORQUE WRENCHES

CROWFOOT WRENCHES

SOCKETS

OTHER TOOLS

## SMC Double Open End Spanner, Metric

Code	mm	C <sub>1</sub> mm	C <sub>2</sub> mm	T mm	L mm	Weight g	Box	Price ¥
SMC0304	3.2×4	10	11	3	82	10	10	570
SMC0405	4×5	12.6	13.5	3.2	91	13	10	570
SMC0507	5.5×7	16.5	19.5	3.7	100	20	10	760

• Nickel Chrome Plating

H **JIS JGA** (5.5 × 7mm)

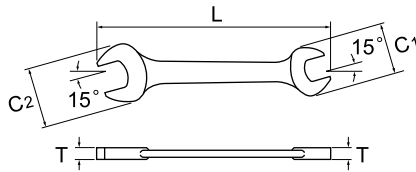

**3Pcs.**

Code **SMCS300** Price **¥2,130**

Set Contains

Double Open End Spanner SMC- 3.2×4, 4×5, 5.5×7

- Weight 60g
- Tool Roll 180 × 100mm



TOOL SETS

SPANNERS

STRIKING FACE WRENCHES

HOOK SPANNERS

DX2000 TOOLS  
HEXAGON KEY WRENCHES

HEXAGON KEY WRENCHES

TORQUE WRENCHES

CROWFOOT WRENCHES

SOCKETS

OTHER TOOLS

# SM Double Open End Spanner, Metric

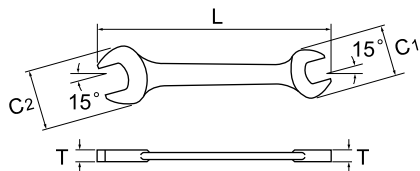

• Nickel Chrome Plating **NIS JQA**

Code	mm	C1 mm	C2 mm	T mm	L mm	Weight g	Price ¥
SM0507	5.5×7	16	19	3.5	102	20	580
SM0607	6×7	16	19	3.5	102	20	580
SM0708	7×8	17	21	4	105	30	600
SM0809	8×9	19	21.5	4	115	30	600
SM0810	8×10	19	21.5	4	115	30	660
SM1012	10×12	21.5	26	4.5	125	45	660
SM1013	10×13	23	27.5	5	130	45	730
SM1113	11×13	23	27.5	5	130	50	730
SM1214	12×14	25	31.5	5.5	140	70	730
SM1317	13×17	32	37.5	6	160	100	930
SM1417	14×17	32	37.5	6	160	100	930
SM1719	17×19	37.5	41.5	6.5	180	135	1,130
SM1921	19×21	40	46	7.5	195	150	1,380
SM2123	21×23	44	48.5	8	205	215	1,430
SM2224	22×24	44	50	8.5	215	220	1,590



SMS0600

**6Pcs.** Code **SMS0600** Price **¥4,560**

Set Contains

Double Open End Spanner	SM- 5.5×7, 8×10, 11×13, 12×14, 13×17, 17×19
-------------------------	---

- Weight 432g
- Metal Holder



SMS0610

**6Pcs.** Code **SMS0610** Price **¥4,850**

Set Contains

Double Open End Spanner	SM- 8×9, 10×12, 12×14, 14×17, 17×19, 21×23
-------------------------	--

- Weight 610g
- Metal Holder
- Blister pack 270 × 70 × 55mm



SMS0620

**6Pcs.** Code **SMS0620** Price **¥4,850**

Set Contains

Double Open End Spanner	SM- 8×10, 11×13, 12×14, 14×17, 17×19, 22×24
-------------------------	---

- Weight 624g
- Metal Holder
- Blister pack 270 × 70 × 55mm

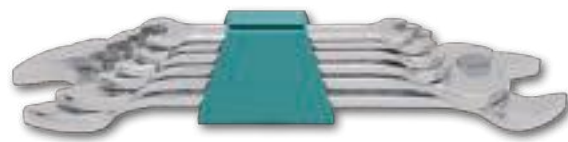

SMS0622

**6Pcs.** Code **SMS0622** Price **¥4,850**

Set Contains

Double Open End Spanner	SM- 5.5×7, 8×10, 11×13, 12×14, 17×19, 22×24
-------------------------	---

- Weight 544g
- Metal Holder
- Blister pack 270 × 70 × 55mm



SMS0800

**8Pcs.** Code **SMS0800** Price **¥6,600**

Set Contains

Double Open End Spanner	SM- 6×7, 8×9, 10×12, 11×13, 14×17, 17×19, 21×23, 22×24
-------------------------	--

- Weight 827g
- Metal Holder
- Storage Box 220 × 60 × 55mm

## CP Combination Wrench, Metric

Code	mm	C mm	D mm	T <sub>1</sub> mm	T <sub>2</sub> mm	L mm	Weight g	Price ¥
CP0005	5.5	13.5	10	3	5	94	14	800
CP0006	6	15.5	10.5	3.5	5	99	14	800
CP0007	7	19.5	13	4	6.5	105	21	800
CP0008	8	19.5	13	4	6.5	105	20	800
CP0009	9	20	14	4.5	6.5	110	25	820
CP0010	10	22	15.3	4.7	6.5	118	31	820
CP0011	11	24	17.5	5.2	7	134	43	940
CP0012	12	25.5	18.5	5.5	7.5	140	48	990
CP0013	13	26.8	20	6.2	8	149	65	1,040
CP0014	14	30.8	22	6.2	8.5	170	84	1,100
CP0015	15	32	23	6.5	9	180	105	1,310
CP0016	16	34.3	24.5	7	9	190	114	1,340
CP0017	17	37	26	7.7	10.5	215	160	1,340
CP0018	18	39.5	28.5	8.2	11.5	235	190	1,520
CP0019	19	39.5	28.5	8.2	11.5	235	182	1,520
CP0020	20	45	31	8.5	12	265	265	1,950
CP0021	21	45	31	8.5	12	265	246	1,950
CP0022	22	46	32.5	9.5	12.5	280	289	2,090
CP0023	23	49.5	35	10	13.5	310	390	2,460
CP0024	24	49.5	35	10	13.5	310	370	2,460
CP0025	25	52	37.5	10.5	14.5	330	405	3,010
CP0026	26	52	37.5	10.5	14.5	330	400	3,010
CP0027	27	58	39.5	10.5	16	360	520	3,290
CP0028	28	59.5	43	11.5	17	387	645	4,380
CP0029	29	59.5	43	11.5	17	387	600	5,500
CP0030	30	59.5	43	11.5	17	387	615	4,380
CP0031	31	66	47.5	12.5	19	420	850	7,900
CP0032	32	66	47.5	12.5	19	420	846	4,860
CP0035	35	73	53	12.5	19.5	465	1,060	8,300
CP0036	36	73	53	12.5	19.5	465	1,050	8,600
CP0038	38	76.5	54.5	13.5	21	490	1,120	11,600
CP0041	41	81.5	61	14.5	22	520	1,600	11,600
CP0046	46	91	69.5	16	24	580	2,150	14,500
CP0050	50	91	69.5	16	24	580	2,100	17,900
CP0054	54	104	80	18	28	635	3,000	34,100
CP0055	55	104	80	18	28	635	2,950	22,900
CP0058	58	115	90	20	31	710	4,210	40,200
CP0060	60	115	90	20	31	710	4,160	27,100

• Nickel Chrome Plating

**JIS JQA** (Except for 0020,0025,0028,  
0031,0058,0060)

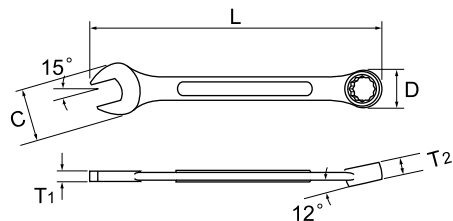

TOOL SETS

SPANNERS

STRIKING-FACE WRENCHES

HOOK SPANNERS

DX2000 TOOLS  
HEXAGON KEY WRENCHES

HEXAGON KEY WRENCHES

TORQUE WRENCHES

CROWFOOT WRENCHES

SOCKETS

OTHER TOOLS

## CP Combination Wrench, Metric

Coming soon



CPS0710

<b>7Pcs.</b>	Code	<b>CPS0710</b>	Price	<b>¥10,400</b>
Set Contains				
Combination Wrench	CP-8, 10, 12, 13, 14, 17, 19			
<ul style="list-style-type: none"> <li>• Weight 750g</li> <li>• Tool Roll 295 × 273mm</li> </ul>				



CPS1010

<b>10Pcs.</b>	Code	<b>CPS1010</b>	Price	<b>¥14,600</b>
Set Contains				
Combination Wrench	CP-8, 10, 12, 13, 14, 17, 19, 21, 22, 24			
<ul style="list-style-type: none"> <li>• Weight 1800g</li> <li>• Tool Roll 420 × 455mm</li> </ul>				



CPS1410

<b>14Pcs.</b>	Code	<b>CPS1410</b>	Price	<b>¥27,300</b>
Set Contains				
Combination Wrench	CP-5.5, 7, 8, 10, 12, 13, 14, 17, 19, 22, 24, 27, 30, 32			
<ul style="list-style-type: none"> <li>• Weight 3500g</li> <li>• Tool Roll 525 × 660mm</li> </ul>				

TOOL SETS

SPANNERS

STRIKING FACE WRENCHES

HOOK SPANNERS

DX2000 TOOLS  
HEXAGON KEY WRENCHES

HEXAGON KEY WRENCHES

TORQUE WRENCHES

CROWFOOT WRENCHES

SOCKETS

OTHER TOOLS



## CPX Combination Wrench, Inches

Code	inch	C mm	D mm	T <sub>1</sub> mm	T <sub>2</sub> mm	L mm	Weight g	Box	Price ¥
CPX0104	1/4	15.5	10.5	3.5	5	99	15	10	1,130
CPX0516	5/16	19.5	13	4	6.5	105	20	10	1,130
CPX0308	3/8	22	15.3	4.7	6.5	118	30	10	1,230
CPX0716	7/16	24	17.5	5.2	7	134	40	10	1,350
CPX0102	1/2	26.8	20	6.2	8	149	60	10	1,500
CPX0916	9/16	30.8	22	6.2	8.5	170	100	10	1,630
CPX0508	5/8	34.3	24.5	7	9	190	120	10	1,850
CPX1116	11/16	37	26	7.7	10.5	215	150	10	2,010
CPX0304	3/4	39.5	28.5	8.2	11.5	235	200	10	2,240
CPX1316	13/16	45	31	8.5	12	265	280	10	2,710
CPX0708	7/8	46	32.5	9.5	12.5	280	300	10	3,020
CPX1516	15/16	49.5	35	10	13.5	310	400	10	3,310
CPX0101	1	52	37.5	10.5	14.5	330	430	10	4,250
CPX1716	1-1/16	58	39.5	11	16	360	530	5	5,300
CPX0908	1-1/8	60	44	12	17	387	700	5	5,900
CPX0504	1-1/4	66	48	12.5	19	420	830	5	7,400
CPX2116	1-5/16	73	53	12.5	19.5	465	1,060	5	-
CPX1108	1-3/8	73	53	12.5	19.5	465	1,060	5	-
CPX2316	1-7/16	76.5	54.5	13.5	21	490	1,120	5	-
CPX0302	1-1/2	76.5	54.5	13.5	21	490	1,120	5	-
CPX2716	1-11/16	85.5	62.5	15.5	23	550	1,700	5	-
CPX0704	1-3/4	85.5	62.5	15.5	23	550	1,700	5	-
CPX2916	1-13/16	91	69.5	16	24	580	2,150	5	-
CPX1508	1-7/8	91	69.5	16	24	580	2,150	5	-
CPX0202	2	91	69.5	16	24	580	2,150	5	-

• Nickel Chrome Plating

inch

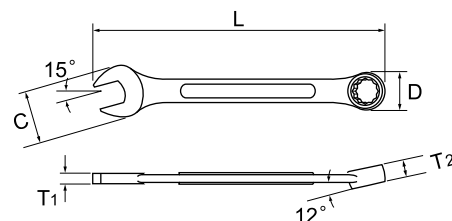

**10Pcs.**

Code **CPXS101** Price **¥21,300**

Set Contains

Combination Wrench	CPX-3/8, 7/16, 1/2, 9/16, 5/8, 11/16, 3/4, 13/16, 7/8, 15/16
--------------------	--

- Weight 1700g
- Tool Roll 380 × 440mm

inch



CPXS101

**14Pcs.**

Code **CPXS141** Price **¥42,400**

Set Contains

Combination Wrench	CPX-3/8, 7/16, 1/2, 9/16, 5/8, 11/16, 3/4, 13/16, 7/8, 15/16, 1, 1-1/16, 1-1/8, 1-1/4
--------------------	---

- Weight 4200g
- Tool Roll 450 × 640mm

inch



CPXS141

# CL Combination Wrench, Metric

**Revo wave®**



Revo wave features an innovative design, never seen before. The curved surface of its distinctive neck fits the worker's hand perfectly, providing excellent workability.

Code	mm	C mm	D mm	T <sub>1</sub> mm	T <sub>2</sub> mm	L mm	Weight g	Box	Price ¥
CL0005	5.5	12.7	10.5	2.9	5	105	13	10	1,130
CL0006	6	13.5	11.0	2.9	5.1	110	15	10	1,130
CL0007	7	15.5	12.4	3.5	5	120	17	10	1,130
CL0008	8	17.5	12.7	3.5	5.7	130	20	10	1,130
CL0009	9	19.5	14	4.2	6.2	136	31	10	1,230
CL0010	10	21.5	15.3	4.8	6.5	152	40	10	1,230
CL0011	11	23.5	17.5	5	7	161	55	10	1,360
CL0012	12	25.5	18.5	5.5	7.5	175	70	10	1,360
CL0013	13	28.0	19.5	6.0	8.0	187	80	10	1,540
CL0014	14	29.5	22.0	6.0	8.5	197	100	10	1,590
CL0015	15	32.5	23.0	6.0	9.0	210	115	5	1,890
CL0016	16	34.5	23.7	6.0	9.5	220	130	5	1,890
CL0017	17	36.0	26.5	7.0	10.5	231	150	5	1,890
CL0018	18	38.0	27.5	7.3	11.0	245	180	5	2,160
CL0019	19	40.0	28.0	7.5	11.5	254	200	5	2,160
CL0021	21	44.5	31.0	8.0	12.5	290	290	5	2,900
CL0022	22	46.5	32.0	8.5	13.0	304	300	5	2,900
CL0024	24	50.5	35.0	9.0	15.0	337	380	5	3,430
CL0026	26	54.5	38.0	10.0	16.0	260	470	5	5,100
CL0027	27	56.0	39.5	10.5	16.0	370	495	5	5,100
CL0030	30	62.0	43.0	11.0	18.0	410	625	5	6,600
CL0032	32	65.5	47.0	11.5	18.5	420	765	5	7,500

• Nickel Chrome Plating

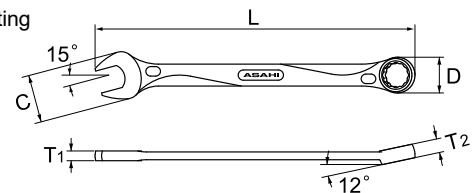

CLS060

<b>6Pcs.</b>	Code	<b>CLS060</b>	Price	<b>¥8,800</b>
Set Contains				
Combination Wrench	CL- 8, 10, 12, 13, 14, 17			

- Weight 490g
- Plastic Holder
- Storage Box 66 × 245 × 43mm



CLS100

<b>10Pcs.</b>	Code	<b>CLS100</b>	Price	<b>¥19,900</b>
Set Contains				
Combination Wrench	CL-8, 10, 12, 13, 14, 17, 19, 21, 22, 24			

- Weight 1750g
- Storage Box 190 × 460 × 40mm



CLS140

<b>14Pcs.</b>	Code	<b>CLS140</b>	Price	<b>¥37,300</b>
Set Contains				
Combination Wrench	CL-5.5, 7, 8, 10, 12, 13, 14, 17, 19, 22, 24, 27, 30, 32			

- Weight 3580g
- Tool Roll 500 × 645mm

## LCW Combination Wrench, Metric

Code	mm	C mm	D mm	T <sub>1</sub> mm	T <sub>2</sub> mm	L mm	Weight g	Box	Price ¥
LCW0005	5.5	12.7	10.5	2.9	5.0	100	11	10	1,130
LCW0006	6	13.0	10.5	2.9	5.0	100	11	10	1,130
LCW0007	7	17.5	12.7	3.5	5.7	105	14	10	1,130
LCW0008	8	17.5	12.7	3.5	5.7	105	13	10	1,130
LCW0009	9	21.5	15.3	4.2	6.5	119	22	10	1,230
LCW0010	10	21.5	15.3	4.2	6.5	119	21	10	1,230
LCW0011	11	24.0	17.5	5.0	7.0	135	30	10	1,380
LCW0012	12	26.0	18.7	5.0	7.5	141	38	10	1,290
LCW0013	13	28.0	20.0	5.4	8.0	151	45	10	1,420
LCW0014	14	29.5	22.0	5.8	8.5	171	60	10	1,420
LCW0015	15	34.5	23.7	6.0	9.5	191	83	10	1,660
LCW0016	16	34.5	23.7	6.0	9.5	191	80	10	1,660
LCW0017	17	36.0	26.5	6.5	10.5	216	100	10	1,760
LCW0018	18	40.0	28.5	7.0	11.5	235	134	10	2,160
LCW0019	19	40.0	28.5	7.0	11.5	235	135	10	2,160
LCW0021	21	46.5	32.0	7.5	12.0	255	200	5	2,760
LCW0022	22	46.5	32.0	7.5	12.0	255	195	5	2,900
LCW0024	24	50.5	34.0	8.0	13.0	280	220	5	3,430
LCW0027	27	56	39.5	10.5	16	340	380	5	4,990
LCW0030	30	62	43	11	18	370	450	5	6,300
LCW0032	32	65.5	47	11.5	18.5	400	600	5	7,300

• Nickel Chrome Plating

JIS JGA

PAT.

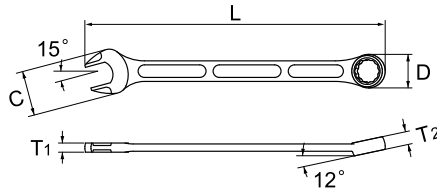

## LIGHTOOL®



12point



LIGHTOOL is both portable and comfortable to use—an effective choice for working at high elevations or for long hours.

Achieved through painstaking testing, its optimized design and advanced forging technology ensure robust strength, which is the true hurdle of weight reduction, and its strength exceeds JIS standards.

**6Pcs.**

Code **LCWS6**

Price **¥8,900**

Set Contains

Combination Wrench LCW-10, 12, 13, 14, 17, 19

• Weight 490g

• Tool Roll 298 × 236mm



TOOL SETS

SPANNERS

STRIKING FACE WRENCHES

HOOK SPANNERS

HEXAGON KEY WRENCHES

HEXAGON KEY WRENCHES

TORQUE WRENCHES

CROWFOOT WRENCHES

SOCKETS

OTHER TOOLS

# LCWU Combination Wrench, Metric

**LIGHTOOL®**



To the distinctive light weight, functional form, and high workability of LIGHTOOL, it adds portability. It's easy to carry around, and suited for use as a key holder or strap.

Code	mm	C mm	D mm	T <sub>1</sub> mm	T <sub>2</sub> mm	L mm	Weight g	Price ¥
LCWU005	5.5	13.5	11	2.9	5.1	48	6.7	1,040
LCWU006	6	13.5	11	2.9	5.1	48	6.4	1,040
LCWU007	7	18	13	3.5	5.7	60	11	1,070
LCWU008	8	18	13	3.5	5.7	60	10	1,190
LCWU010	10	21	15.3	4.2	6.5	68	15	1,280
LCWU012	12	24	19	5.0	7.5	76	25	1,360
LCWU013	13	28	20	5.4	8	87	33	1,500
LCWU014	14	29.5	22	5.8	8.5	95	44	1,540
LCWU015	15	34.5	23.7	6.0	8.5	105	60	1,800
LCWU016	16	34.5	23.7	6.0	8.5	105	61	1,800
LCWU017	17	36	26.5	6.5	10.5	115	71	1,890

• Nickel Chrome Plating

(PAT.)

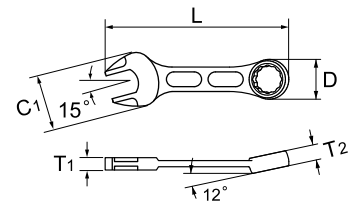

LCWUS30

<b>3Pcs.</b>	Code	<b>LCWUS30</b>	Price	<b>¥3,640</b>
Set Contains				
Combination Wrench	LCWU- 8, 10, 12			

- Weight 55g
- Blister pack 110 × 70 × 28mm



LCWUS31

<b>3Pcs.</b>	Code	<b>LCWUS31</b>	Price	<b>¥3,310</b>
Set Contains				
Combination Wrench	LCWU- 5.5, 6, 7			

- Weight 26g
- Blister pack 110 × 70 × 28mm



LCWUS60

<b>6Pcs.</b>	Code	<b>LCWUS60</b>	Price	<b>¥7,700</b>
Set Contains				
Combination Wrench	LCWU- 8, 10, 12, 13, 14, 17			

- Weight 195g
- Blister pack 157 × 70 × 50mm

TOOL SETS  
SPANNERS  
STRIKING FACE WRENCHES  
HOOK SPANNERS  
DX2000 TOOLS  
HEXAGON KEY WRENCHES  
HEXAGON KEY WRENCHES  
TORQUE WRENCHES  
CROWFOOT WRENCHES  
SOCKETS  
OTHER TOOLS

## RS Ring Spanner, Metric

Code	mm	D mm	T mm	L mm	Weight g	Icon	Price ¥
RS0010	10	16.5	8.5	163	50	10	960
RS0011	11	20	10	165	70	10	960
RS0012	12	20	10	165	70	10	1,010
RS0013	13	23	11	186	90	10	1,010
RS0014	14	23	11	186	90	10	1,010
<b>NEW</b> RS0015	15	25.5	11	195	105	10	1,130
<b>NEW</b> RS0016	16	25.5	11	195	105	10	1,130
<b>NEW</b> RS0017	17	26.5	11.5	203	130	10	1,030
RS0018	18	30	12.5	215	160	10	1,130
RS0019	19	30	12.5	215	160	10	1,070
RS0021	21	36.5	16	248	270	10	1,170
RS0022	22	36.5	16	248	270	10	1,260
RS0023	23	36.5	16	248	270	10	1,520
RS0024	24	36.5	16	248	260	10	1,520
RS0026	26	40	17	265	330	10	1,640
RS0027	27	40	17	265	320	10	1,660
RS0029	29	47	18.5	288	500	10	2,230
RS0030	30	47	18.5	288	500	10	2,230
RS0032	32	47	18.5	288	520	10	2,290
RS0035	35	54	21	312	670	5	2,700
RS0036	36	54	21	312	680	5	2,870
RS0038	38	54	21	312	680	5	3,800
RS0041	41	65.5	24	378	1,140	5	4,090
RS0046	46	65.5	24	378	1,040	5	5,600
RS0050	50	79.5	33	450	1,900	2	7,000
RS0054	54	79.5	33	450	1,850	2	11,800
RS0055	55	79.5	33	450	1,850	2	12,500
RS0058	58	93	40	521	3,130	2	14,900
RS0060	60	93	40	521	3,130	2	16,000
RS0063	63	93	40	521	3,000	2	19,500
RS0065	65	93	40	521	2,800	2	21,200
RS0067	67	110	45	555	4,000	2	23,300
RS0070	70	110	45	555	4,000	2	28,500
RS0071	71	110	45	555	3,600	2	30,000
RS0075	75	110	45	555	3,600	2	33,000
RS0077	77	110	45	555	3,600	2	35,000
RS0080	80	127	51	663	6,200	-	38,800
RS0085	85	127	51	663	6,200	-	70,100
RS0090	90	148	53	704	7,900	-	93,400
RS0095	95	148	53	704	7,900	-	99,400
RS0100	100	148	53	704	7,900	-	108,400
RS0105	105	160	55	740	9,400	-	111,400
RS0110	110	160	55	740	9,400	-	120,500
RS0115	115	172	55	776	10,700	-	-
RS0120	120	172	55	776	10,700	-	-



The 40° curved single-end ring spanner is ideal for working in tight spaces.

Code	mm	D mm	T mm	L mm	Weight g	Icon	Price ¥
RS0125	125	185	60	813	13,400	-	-
RS0130	130	185	60	813	13,400	-	-
RS0135	135	198	60	849	-	-	-
RS0140	140	198	60	849	-	-	-
RS0145	145	211	65	886	-	-	-
RS0150	150	211	65	886	-	-	-
RS0155	155	224	65	922	-	-	-
RS0160	160	224	65	922	-	-	-
RS0165	165	237	70	959	-	-	-
RS0170	170	237	70	959	-	-	-
RS0175	175	250	70	995	-	-	-
RS0180	180	250	70	995	-	-	-
RS0185	185	263	75	1,032	-	-	-
RS0190	190	263	75	1,032	-	-	-
RS0195	195	276	75	1,068	-	-	-
RS0200	200	276	75	1,068	-	-	-

- Nickel Chrome Plating ( ~ 0032 )
- Cathodic Electrodeposition (0035 ~ )
- Special Order (0115 ~ )

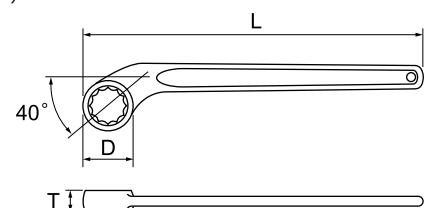



## RD Ring Spanner, Metric



Code	mm	D mm	T mm	L mm	Weight g	Price ¥
RD0017	17	27	23.5	212.5	148	1,520
RD0019	19	32	25	233	190	1,730
RD0021	21	33	25.5	241.5	194	1,930
RD0022	22	33.5	25.5	249	214	1,930
RD0024	24	37	29	261.5	277	2,240

• Nickel Chrome Plating

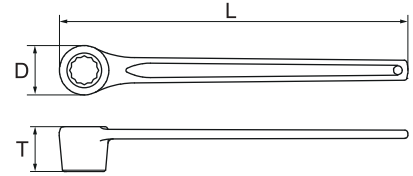

Allows access to fasten bolts and nuts too deep to be reached by conventional ring spanners. The larger contact surface makes it easier to transmit force and less likely to damage the surface of long nuts, etc.

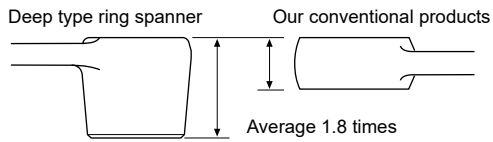

## OF Offset Wrench, Metric

Code	mm	D <sub>1</sub> mm	D <sub>2</sub> mm	T <sub>1</sub> mm	T <sub>2</sub> mm	L mm	Weight g	Price ¥	
OF0809	8×9	12.5	15.5	5.5	6.5	166	40	10	1,610
OF0810	8×10	12.5	15.5	5.5	6.5	166	40	10	1,610
OF1011	10×11	15.5	18.5	6.5	7.5	190	60	10	1,730
OF1012	10×12	15.5	19	6.5	7.5	190	60	10	1,620
OF1013	10×13	17	19.5	7.5	8	190	80	10	1,650
OF1113	11×13	17	19.5	7.5	8	190	80	10	1,740
OF1214	12×14	19	22	7.5	8.5	215	90	10	1,750
OF1317	13×17	21	25	8.5	10	243	140	10	1,940
OF1417	14×17	21	25	8.5	10	243	140	10	1,940
OF1719	17×19	25	28	10	11.5	276	190	10	2,170
OF1721	17×21	26.5	32	11.5	12	313	290	10	2,610
OF1921	19×21	28	32	11.5	12	314	310	10	2,740
OF1922	19×22	28	32	11.5	12	314	310	10	2,740
OF1924	19×24	29.5	34.5	12	13	332	340	10	2,900
OF2123	21×23	32	34.5	12	13	333	360	10	3,280
OF2126	21×26	32.5	38.5	13	13.5	365	450	5	3,550
OF2224	22×24	32	34.5	12	13	333	360	10	3,450
OF2326	23×26	34.5	38.5	13	13.5	366	450	5	3,870
OF2427	24×27	34.5	38.5	13	13.5	366	450	5	4,330
OF2430	24×30	38.5	46	13.5	16	392	660	5	4,450
OF2629	26×29	38.5	46	13.5	16	392	650	5	5,400
OF2632	26×32	38.5	46	13.5	16	392	600	5	5,100
OF2730	27×30	38.5	46	13.5	16	392	650	5	5,100
OF2932	29×32	46	51	16	17	428	870	5	5,700
OF3032	30×32	46	51	16	17	428	870	5	5,600
OF3235	32×35	46	51	16	17	428	870	5	6,300
OF3236	32×36	46	51	16	17	428	870	5	6,300
OF3541	35×41	51	58	17	18	455	1,120	5	8,000
OF3641	36×41	51	58	17	18	455	1,120	5	8,200

• Nickel Chrome Plating

**JIS JQA** (~ OF2427)

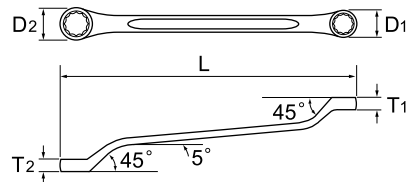

TOOL SETS

SPANNERS

STRIKING FACE WRENCHES

HOOK SPANNERS

DX2000 TOOLS  
HEXAGON KEY WRENCHES

HEXAGON KEY WRENCHES

TORQUE WRENCHES

CROWFOOT WRENCHES

SOCKETS

OTHER TOOLS

# OL Offset Wrench, Metric

**Revowave®**



Revowave features an innovative design, never seen before. The curved surface of its distinctive neck fits the worker's hand perfectly, providing excellent workability.



Code	mm	D <sub>1</sub> mm	D <sub>2</sub> mm	T <sub>1</sub> mm	T <sub>2</sub> mm	L mm	Weight g	Box	Price ¥
OL0810	8 × 10	12.7	15.5	6	6.5	180	47	10	1,700
OL1012	10 × 12	15.3	18.5	6.5	7.6	195	64	10	1,810
OL1113	11 × 13	17	19.5	7.5	8	210	87	10	1,940
OL1214	12 × 14	18.5	21	7.6	9.5	224	102	10	1,960
OL1417	14 × 17	21	25.5	9.5	10.7	256	169	10	2,210
OL1719	17 × 19	25.5	28	10.7	12.2	287	220	10	2,620
OL1921	19 × 21	28	30.5	12.2	13.2	314	300	10	3,220
OL2224	22 × 24	32	35	13.2	14	334	353	10	3,770

• Nickel Chrome Plating

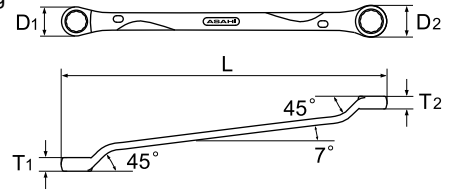

<b>6Pcs.</b>	Code	<b>OLS060</b>	Price	<b>¥15,000</b>
Set Contains				
Offset Wrench	OL- 8 × 10, 10 × 12, 11 × 13, 14 × 17, 19 × 21, 22 × 24			

- Weight 1200g
- Storage Box 175 × 375 × 40mm

## FW Flare Nut Wrench, Metric

Code	mm	D1 mm	D2 mm	G1 mm	G2 mm	T1 mm	T2 mm	L mm	Weight g	Price ¥
FW0810	8×10	20	22	5	6.5	8.5	9	154	68	5, 1,360
FW1011	10×11	20	22	6.5	7.5	8.5	9	154	65	5, 1,360
FW1012	10×12	20	22	6.5	8	8.5	9	154	65	5, 1,360
FW1113	11×13	24	26	7.5	8.5	10	11	182	115	5, 1,500
FW1214	12×14	24	26	8	9	10	11	182	100	5, 1,500
FW1417	14×17	28	30	9	11.2	11.5	12	213	155	5, 1,700
FW1922	19×22	32.5	37	12.5	16	14	15	242	253	5, 2,540

• Nickel Chrome Plating

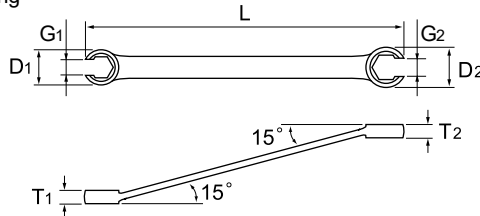

Allows fastening of nuts along a pipe.  
Handy for pipe joint work, car maintenance, and similar applications.

## LOF Offset Wrench, Metric

Code	mm	D1 mm	D2 mm	T1 mm	T2 mm	L mm	Weight g	Price ¥
LOF0810	8×10	12.7	15.3	6	6.5	180	30	10, 1,750
LOF1012	10×12	15.3	18.5	6.5	7.6	195	50	10, 1,800
LOF1113	11×13	17	19.5	7.5	8	210	70	10, 1,850
LOF1214	12×14	18.5	21	7.6	9.5	220	80	10, 1,850
LOF1315	13×15	19.5	22.5	8	10	234	97	10, 2,060
LOF1417	14×17	21	25	9.5	10.7	255	120	10, 2,070
LOF1618	16×18	24	27	10.5	11.5	268	155	10, 2,460
LOF1719	17×19	25	28	10.7	12.2	280	175	10, 2,310
LOF1921	19×21	28	30.5	12.4	13.4	314	245	10, 2,940
LOF2224	22×24	32	35	13.2	14	333	290	10, 3,670

• Nickel Chrome Plating

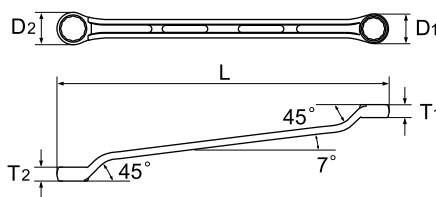

**LIGHTOOL®**



LIGHTOOL is both portable and comfortable to use—an effective choice for working at high elevations or for long hours. Achieved through painstaking testing, its optimized design and advanced forging technology ensure robust strength, which is the true hurdle of weight reduction, and its strength exceeds JIS standards.

**6Pcs.**

Code **LOFS601**

Price **¥14,600**

Set Contains

Offset Wrench LOF-8 ×10, 10×12, 11×13, 14×17, 19×21, 22×24

- Weight 1120g
- Storage Box 175 × 375 × 40mm



# Striking Face Wrenches



mm	Width across flat
24	●
27	●
30	●
32	●
35	●
36	●
38	●
41	●
46	●
50	●
54	●
55	●
58	●
60	●
63	●
65	●
67	●
70	●
71	●
75	●
77	●
80	●
85	●
90	●
95	●
100	●
105	●
110	●
115	●
120	●
125	●
130	●
135	●
145	●
150	●
155	●
165	●
170	●
175	●
180	●
185	●
190	●
200	●

## Inch

inch	Width across flat
DRX	
15/16	●
1	●
1-1/16	●
1-1/8	●
1-1/4	●
1-5/16	●
1-3/8	●
1-7/16	●
1-1/2	●
1-5/8	●
1-11/16	●
1-3/4	●
1-13/16	●
1-7/8	●
2	●



mm	Width across flat
30	●
32	●
35	●
36	●
41	●
46	●
50	●
54	●
55	●
58	●
60	●
63	●
65	●
67	●
70	●
71	●
75	●
80	●
85	●
90	●
95	●
100	●
105	●
110	●
115	●
120	●
125	●
130	●
135	●
145	●
150	●
155	●
165	●
170	●
175	●
180	●
190	●
200	●
210	●



mm	Width across flat
19.0	●
25.4	●
38.1	●

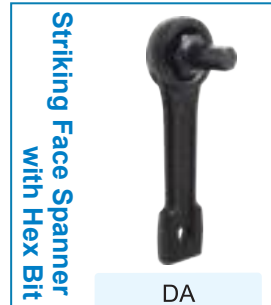

mm	Width across flat
14	●
17	●
19	●
22	●
24	●
27	●
32	●
36	●
41	●
46	●



## DR Striking Face Ring Spanner, Metric

Code	mm	D mm	T mm	t mm	L mm	Weight g	Box	Price ¥
DR0024	24	45	18	13.5	185	350	2	5,200
DR0027	27	45	18	13.5	185	340	2	5,300
DR0030	30	55	20	15	197	520	2	5,700
DR0032	32	55	20	15	197	520	2	5,800
DR0035	35	55	20	15	197	520	2	6,200
DR0036	36	66	22	16	223	940	2	6,500
DR0038	38	66	22	16	223	940	2	7,100
DR0041	41	66	22	16	223	940	2	7,100
DR0046	46	80	27	18	250	1,330	2	8,400
DR0050	50	80	27	18	250	1,330	2	9,800
DR0054	54	90	27	19	275	1,830	2	12,800
DR0055	55	90	27	19	275	1,830	2	12,800
DR0058	58	90	27	19	275	1,830	2	14,500
DR0060	60	104	32	24	302	2,630	2	16,200
DR0063	63	104	32	24	302	2,630	2	18,200
DR0065	65	104	32	24	302	2,630	2	18,200
DR0067	67	104	32	24	302	2,630	2	20,200
DR0070	70	120	35	28	350	4,500	2	22,800
DR0071	71	120	35	28	350	4,500	2	25,900
DR0075	75	120	35	28	350	4,500	2	26,500
DR0077	77	120	35	28	350	4,500	2	31,700
DR0080	80	127	39	28	354	4,400	2	32,500
DR0085	85	144	41	31	397	7,000	2	34,300
DR0090	90	144	41	31	397	7,000	2	41,400
DR0095	95	157	50	34	419	8,500	-	41,400
DR0100	100	157	50	34	419	8,500	-	51,600
DR0105	105	183	55	36	441	11,200	-	58,900
DR0110	110	183	55	36	441	11,200	-	71,600
DR0115	115	183	55	36	441	11,200	-	83,100
DR0120	120	185	60	38	480	13,300	-	-
DR0125	125	195	60	38	490	13,000	-	-
DR0130	130	198	60	38	492	15,500	-	-
DR0135	135	204	65	40	512	17,000	-	-
DR0145	145	217	65	40	554	18,000	-	-
DR0150	150	223	65	44	577	21,000	-	-
DR0155	155	230	65	44	585	21,000	-	-
DR0165	165	242	65	48	609	24,800	-	-
DR0170	170	254	65	48	630	-	-	-
DR0175	175	254	65	48	630	-	-	-
DR0180	180	260	70	48	648	-	-	-
DR0185	185	278	75	52	692	-	-	-
DR0190	190	278	75	52	692	-	-	-
DR0200	200	293	75	52	712	-	-	-

- Cathodic Electrodeposition
- Special Order (0120 ~ )

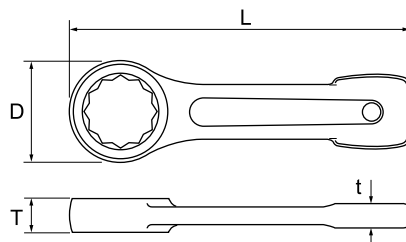

### 【 How to use 】

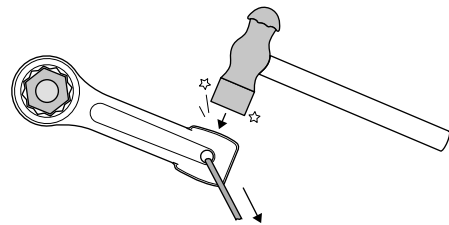

Thread a rope through the hole of the handle and pull it to a tightening direction hammering the striking surface of the spanner.

## DRX Striking Face Ring Spanner, Inches

inch



Code	inch	D mm	T mm	t mm	L mm	Weight g		Price ¥
DRX1516	15/16	45	18	13.5	185	340	2	7,400
DRX0101	1	45	18	13.5	185	340	2	7,400
DRX1716	1-1/16	45	18	13.5	185	340	2	7,400
DRX0908	1-1/8	55	20	15	197	520	2	8,700
DRX0504	1-1/4	55	20	15	197	520	2	8,700
DRX2116	1-5/16	55	20	15	197	520	2	8,700
DRX1108	1-3/8	55	20	15	197	520	2	8,700
DRX2316	1-7/16	66	22	16	223	940	2	9,900
DRX0302	1-1/2	66	22	16	223	940	2	9,900
DRX1308	1-5/8	66	22	16	223	940	2	9,900
DRX2716	1-11/16	80	27	18	250	1,330	2	13,700
DRX0704	1-3/4	80	27	18	250	1,330	2	13,700
DRX2916	1-13/16	80	27	18	250	1,330	2	13,700
DRX1508	1-7/8	80	27	18	250	1,330	2	13,700
DRX0201	2	80	27	18	250	1,330	2	13,700

• Cathodic Electrodeposition

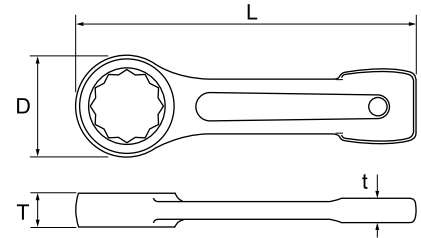

TOOL SETS

SPANNERS

STRIKING FACE WRENCHES

HOOK SPANNERS

DX2000 TOOLS  
HEXAGON KEY WRENCHES

HEXAGON KEY WRENCHES

TORQUE WRENCHES

CROWFOOT WRENCHES

SOCKETS

OTHER TOOLS

## DS Striking Face Open End Spanner, Metric

Code	mm	C mm	T mm	t mm	L mm	Weight g	Price ¥
DS0030	30	82.6	19	14	222	830	6,400
DS0032	32	82.6	19	14	222	830	6,400
DS0035	35	82.6	19	14	222	830	6,400
DS0036	36	82.6	19	14	222	830	7,400
DS0041	41	82.6	19	14	222	800	9,600
DS0046	46	113	22	18	266	1,600	11,400
DS0050	50	113	22	18	266	1,600	14,200
DS0054	54	113	22	18	266	1,500	15,900
DS0055	55	113	22	18	266	1,500	16,200
DS0058	58	150	32	24	324	4,200	18,700
DS0060	60	150	32	24	324	4,200	20,900
DS0063	63	150	32	24	324	4,200	26,500
DS0065	65	150	32	24	324	4,000	28,000
DS0067	67	150	32	24	324	4,000	30,500
DS0070	70	181	38	28	381	7,500	33,300
DS0071	71	181	38	28	381	7,500	38,700
DS0075	75	181	38	28	381	7,500	41,100
DS0077	77	181	38	28	381	7,500	45,100
DS0080	80	181	38	28	381	7,500	45,100
DS0085	85	208	45	30	429	10,000	52,400
DS0090	90	208	45	30	429	10,000	62,000
DS0095	95	208	45	30	429	10,000	63,400
DS0100	100	220	50	34	450	12,000	96,700
DS0105	105	230	50	34	470	13,000	96,700
DS0110	110	240	50	34	490	13,800	107,500
DS0115	115	245	55	34	510	14,000	127,400
DS0120	120	255	55	36	520	20,200	-
DS0125	125	270	60	36	537	22,000	-
DS0130	130	270	60	36	537	23,000	-
DS0135	135	280	60	36	560	24,000	-
DS0145	145	295	65	42	606	30,000	-
DS0150	150	305	65	42	631	32,000	-
DS0155	155	315	65	42	642	34,000	-
DS0165	165	330	75	48	671	-	-
DS0170	170	340	75	48	691	-	-
DS0175	175	360	75	48	712	-	-
DS0180	180	360	75	48	717	-	-
DS0185	185	380	75	52	759	-	-
DS0190	190	380	75	52	764	-	-
DS0200	200	400	80	54	787	-	-
DS0210	210	420	90	54	813	-	-

- Cathodic Electrodeposition
- Special Order (0120 ~ )

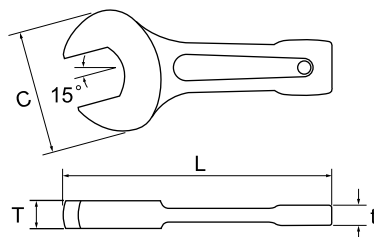

TOOL SETS

SPANNERS

STRIKING FACE WRENCHES

HOOK SPANNERS

DX2000 TOOLS  
HEXAGON KEY WRENCHES

HEXAGON KEY WRENCHES

TORQUE WRENCHES

GROWFOOT WRENCHES

SOCKETS

OTHER TOOLS

## DH Striking Face Spanner with Square Bit



Code	□ mm	D mm	T mm	t mm	L mm	Weight g	Price ¥
DH0600	19.0	66	48	16	223	1,250	29,800
DH0800	25.4	66	52	16	223	1,300	31,400
DH1000	38.1	80	71	18	250	2,200	40,300

- Cathodic Electrodeposition
- Interchangeable
- Special Order

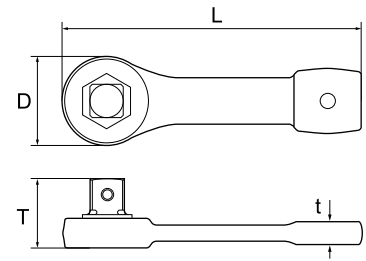

## DA Striking Face Spanner with Hex Bit, Metric



Code	□ mm	D mm	T mm	t mm	L mm	Weight g	Price ¥
DA1400	14	55	60	15	197	760	25,800
DA1700	17	55	60	15	197	780	25,800
DA1900	19	66	67	16	223	1,280	26,800
DA2200	22	66	67	16	223	1,320	26,800
DA2400	24	66	67	16	223	1,350	26,800
DA2700	27	80	77	18	250	1,830	34,900
DA3200	32	80	77	18	250	1,930	34,900
DA3600	36	80	77	18	250	2,030	34,900
DA4100	41	90	82	19	275	2,830	44,100
DA4600	46	90	82	19	275	2,980	44,100

- Cathodic Electrodeposition
- Interchangeable
- Special Order

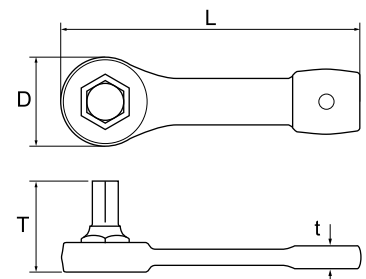

## 【 Exchange Bit 】





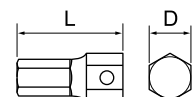

Code	□ mm	D mm	L mm	Weight g		Price ¥
DAT1400	14	32	60	210	-	15,800
DAT1700	17	32	60	230	-	15,800
DAT1900	19	36	67	326	-	16,300
DAT2200	22	36	67	363	-	16,300
DAT2400	24	36	67	385	-	16,800
DAT2700	27	46	77	670	-	17,900
DAT3200	32	46	77	763	-	18,400
DAT3600	36	46	77	842	-	18,900
DAT4100	41	50	82	1,120	-	22,600
DAT4600	46	50	82	1,270	-	22,600

- For DA
- Black Oxide Finish



# Hook Spanner

Hook Spanner		
		FK
 mm Bearing nut diameter		
12~14	●	
16~20	●	
20~22	●	
25~28	●	
30~32	●	
34~38	●	
38~45	●	
40~42	●	
45~48	●	
45~52	●	
50~55	●	
52~58	●	
58~65	●	
65~70	●	
65~75	●	
70~75	●	
75~80	●	
75~85	●	
80~85	●	
85~92	●	
92~100	●	
98~110	●	
105~115	●	
120~130	●	
140~150	●	
155~165	●	
175~195	●	
200~220	●	
230~250	●	
260~280	●	
290~320	●	
320~345	●	
350~375	●	
380~400	●	

Hook Spanner, Pin Type		
		FP
 mm Bearing nut diameter		
12~14		
16~20		
20~22		
25~28	●	
30~32	●	
34~38	●	
38~45		
40~42	●	
45~48	●	
45~52		
50~55	●	
52~58		
58~65	●	
65~70	●	
65~75		
70~75	●	
75~80		
75~85		
80~85	●	
85~92	●	
92~100	●	
98~110		
105~115	●	
120~130		
140~150		
155~165		
175~195		
200~220		
230~250		
260~280		
290~320		
320~345		
350~375		
380~400		



# FK Hook Spanner



## [How to use]

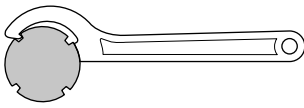

• Hooks into the groove of a grooved round nut.



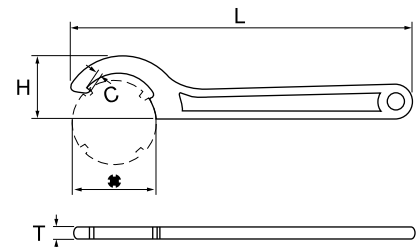

Code	mm	C mm	T mm	H mm	L mm	Weight g	Box	Price ¥
FK0012	12~14	2	4	12	108	24	10	980
FK0016	16~20	2	4	12	108	24	10	980
FK0020	20~22	2	4	12	108	24	10	980
FK0025	25~28	2.3	5	21	136	48	10	980
FK0030	30~32	2.3	5	21	136	48	10	1,000
FK0034	34~38	2.5	6	28	160	88	10	1,100
FK0038	38~45	2.5	6	30	173	95	10	1,140
FK0040	40~42	2.5	6	30	173	102	10	1,140
FK0045	45~48	2.5	6.5	36	196	142	10	1,270
FK0045N	45~52	2.5	6.5	36	196	146	10	1,320
FK0052	50~55	2.5	6.5	41	208	156	10	1,540
FK0052N	52~58	2.5	6.5	41	208	158	10	1,630
FK0058	58~65	3	7.5	46	232	217	10	1,770
FK0065	65~70	3	7.5	46	232	217	10	1,820
FK0065N	65~75	3.5	8	52	247	262	10	2,020
FK0070	70~75	3.5	8	52	247	265	10	1,920
FK0075	75~80	3.5	8	52	247	253	10	2,000
FK0075N	75~85	3.5	8.5	62	271	378	10	2,390
FK0080	80~85	3.5	8.5	62	271	386	10	2,390
FK0085	85~92	3.5	8.5	62	271	370	10	2,590
FK0092	92~100	4	8.5	68	286	404	10	2,680
FK0098	98~110	4	10	82	333	666	5	3,660
FK0105	105~115	4	10	82	333	665	5	3,570
FK0120	120~130	4.5	10	82	333	644	5	3,890
FK0140	140~150	5.5	10.5	100	385	940	5	6,300
FK0155	155~165	5.5	10.5	100	385	930	5	6,900
FK0175	175~195	6.5	12	130	466	1,730	-	13,500
FK0200	200~220	7.5	12	130	466	1,750	-	14,900
FK0230	230~250	8.5	16	162	567	3,400	-	19,300
FK0260	260~280	8.5	16	162	567	3,400	-	19,800
FK0290	290~320	12	16	196	610	-	-	-
FK0320	320~345	12	16	215	640	-	-	-
FK0350	350~375	12	16	235	680	-	-	-
FK0380	380~400	14	19	255	741	-	-	-

- Cathodic Electrodeposition
- Special Order (0290 ~ )



# FP Hook Spanner, Pin Type

Code	 mm	d mm	ℓ mm	T mm	H mm	L mm	Weight g		Price ¥
FP2528	25~28	2.5	2	5	21	136	47	10	1,700
FP3032	30~32	2.5	2	5	21	136	46	10	1,700
FP3438	34~38	3.5	3.5	6	28	160	88	10	1,780
FP4042	40~42	3.5	3.5	6	30	173	102	10	1,930
FP4548	45~48	4.5	4	6.5	34	195	143	10	2,210
FP5255	50~55	4.5	4	6.5	40	208	156	10	2,350
FP5865	58~65	4.5	5	7.5	46	230	220	10	2,570
FP6570	65~70	4.5	5	7.5	46	230	224	10	2,740
FP7075	70~75	5.5	5	8	52	246	262	10	2,740
FP8085	80~85	5.5	6	8.5	62	270	388	10	3,430
FP8592	85~92	5.5	6	8.5	62	270	369	10	3,550
FP9298	92~100	6	6	8.5	68	286	410	10	3,680
FPP105	105~115	6	6	10	82	333	674	5	5,800

• Cathodic Electrodeposition

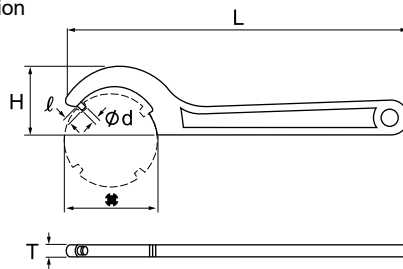

## [Precautions for use]

• Use for round nuts with holes.



Do not attach the spanner into the narrow groove as it may damage the spanner.

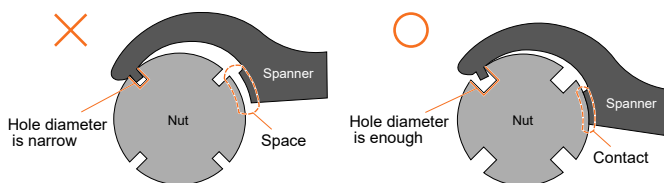

TOOL SETS

SPANNERS

STRIKING FACE WRENCHES

HOOK SPANNERS

DX2000 TOOLS  
HEXAGON KEY WRENCHES

HEXAGON KEY WRENCHES

TORQUE WRENCHES

CROWFOOT WRENCHES

SOCKETS

OTHER TOOLS

# DX2000TOOLS Hexagon Key Wrenches

List of products

[Metric]

[Inch]

		AQ	AQU	AQKU	AZ	AZU	AY	AX	DY	DZ	DV	DV	DW	DW	AQK	AZK	AYK	AQX	AQKX
Length	Long	●	●	●			●		●		●	●			●		●	●	●
	Short				●	●		●		●			●	●		●			●
Functions	Ball Point	●	●	●	●	●					●	●	●	●	●	●			●
	<b>Auroline®</b> Different Colors For Each Size		●	●		●													
	<b>Daxkey Wrench</b> Half-Length Hex Key Ends								●	●	●	●	●	●					
	Double-Ended								●	●									
	Bent On Edges											●	●	●	●				
	Catcher Ball			●									●		●	●	●	●	
Size mm	1.5	●	●		●	●	●	●	●	●	●		●						
	2	●	●		●	●	●	●	●	●	●		●						
	2.5	●	●		●	●	●	●	●	●	●		●						
	3	●	●	●	●	●	●	●	●	●		●		●	●	●	●	●	●
	4	●	●	●	●	●	●	●	●	●		●		●	●	●	●	●	●
	5	●	●	●	●	●	●	●	●	●		●		●	●	●	●	●	●
	6	●	●	●	●	●	●	●	●	●		●		●	●	●	●	●	●
	8	●	●	●	●	●	●	●	●	●		●		●	●	●	●	●	●
	10	●	●	●	●	●	●	●	●	●		●		●	●	●	●	●	●
	12	●			●		●	●				●							
	14	●			●		●	●				●							
17	●					●					●								
19	●					●					●								

# Ball Point

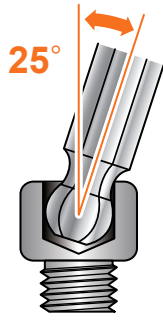

25°

Designed to be used at an angle off-axis to the screw by 25 degrees, so as to avoid obstacles.

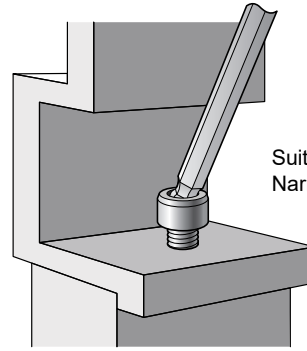

Suitable for Working in Narrow Spaces

## Long type

Code	Ø mm	L mm	ℓ mm	Weight g		Price ¥
AQ0150	1.5	90	14	1.4	10	790
AQ0200	2	100	16	3	10	790
AQ0250	2.5	112	18	5.2	10	810
AQ0300	3	126	20	8.8	10	810
AQ0400	4	142	23	16	10	910
AQ0500	5	160	28	30	10	1,070
AQ0600	6	180	32	50	10	1,400
AQ0800	8	200	36	100	10	1,780
AQ1000	10	224	40	178	10	2,430
AQ1200	12	250	45	290	3	3,820
AQ1400	14	280	56	448	3	4,770
AQ1700	17	320	63	754	4	8,200
AQ1900	19	360	70	1,055	4	10,800

- Special Alloy Steel ( ~ 0600 )
- Alloy Steel ( 0800 ~ )
- Nickel Chrome Plating
- Blister pack ( 0150 ~ 1400 )

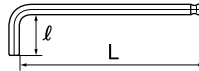

Code	Ø inch	L mm	ℓ mm	Weight g		Price ¥
AQX0116	1/16	90	14	1.5	10	820
AQX0564	5/64	100	16	3	10	820
AQX0332	3/32	112	18	5	10	850
AQX0108	1/8	126	20	9.5	10	880
AQX0532	5/32	142	23	16.5	10	990
AQX0316	3/16	160	28	28	10	1,150
AQX0732	7/32	170	30	41	10	1,480
AQX0104	1/4	180	32	58	10	1,480
AQX0516	5/16	200	36	99	10	1,850
AQX0308	3/8	224	40	163	10	2,740

- Special Alloy Steel ( ~ 0316 )
- Alloy Steel ( 0732 ~ )
- Nickel Chrome Plating

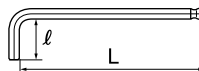

inch



TOOL SETS

SPANNERS

STRIKING FACE WRENCHES

HOOK SPANNERS

DX2000 TOOLS  
HEXAGON KEY WRENCHES

HEXAGON KEY WRENCHES

TORQUE WRENCHES

CROWFOOT WRENCHES

SOCKETS

OTHER TOOLS

# Ballpoint Hexagon Key Wrench Long type



AQS0710

**7Pcs.**

1.5 mm 2 mm 2.5 mm 3 mm 4 mm 5 mm 6 mm

Code	mm	Weight g	Box	Price ¥
AQS0710	AQ-1.5, 2, 2.5, 3, 4, 5, 6	140	10	6,450

- Plastic Holder
- Blister pack 240 × 75 × 15mm



AQS0810

**8Pcs.**

3 mm 4 mm 5 mm 6 mm 8 mm 10 mm 12 mm 14 mm

Code	mm	Weight g	Box	Price ¥
AQS0810	AQ-3, 4, 5, 6, 8, 10, 12, 14	1,240	—	16,170

- Tool Roll 310 × 285mm



AQS0880

**8Pcs.**

1.5 mm 2 mm 2.5 mm 3 mm 4 mm 5 mm 6 mm 8 mm

Code	mm	Weight g	Box	Price ¥
AQS0880	AQ-1.5, 2, 2.5, 3, 4, 5, 6, 8	252	5	8,240

- Plastic Holder
- Blister pack 265 × 90 × 18mm



AQS0900

**9Pcs.**

1.5 mm 2 mm 2.5 mm 3 mm 4 mm 5 mm 6 mm 8 mm 10 mm

Code	mm	Weight g	Box	Price ¥
AQS0900	AQ-1.5, 2, 2.5, 3, 4, 5, 6, 8, 10	835	—	15,300

- Plastic holder with the magnet

TOOL SETS

SPANNERS

STRIKING FACE WRENCHES

HOOK SPANNERS

DX2000 TOOLS  
HEXAGON KEY WRENCHES

HEXAGON KEY WRENCHES

TORQUE WRENCHES

CROWFOOT WRENCHES

SOCKETS

OTHER TOOLS



# Ballpoint Hexagon Key Wrench

## Long type

**9Pcs.**

1.5 mm 2 mm 2.5 mm 3 mm 4 mm 5 mm 6 mm 8 mm 10 mm

Code	mm	Weight g	Box	Price ¥
AQS0910	AQ-1.5, 2, 2.5, 3, 4, 5, 6, 8, 10	450	5	10,530

- Plastic Holder
- Blister pack 290 × 90 × 30mm



AQS0910

**9Pcs.**

1.5 mm 2 mm 2.5 mm 3 mm 4 mm 5 mm 6 mm 8 mm 10 mm

Code	mm	Weight g	Box	Price ¥
AQTS910	AQ-1.5, 2, 2.5, 3, 4, 5, 6, 8, 10	430	1	11,200

- Connect Holder
- Casing 305 × 65 × 35mm

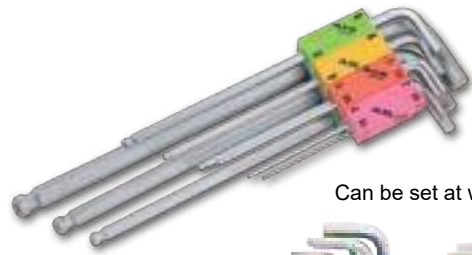

AQTS910

Can be set at will.

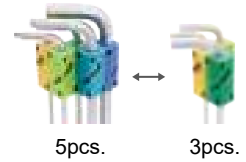

5pcs.

3pcs.

**9Pcs.**

1/16 5/64 3/32 1/8 5/32 3/16 1/4 5/16 3/8

Code	inch	Weight g	Box	Price ¥
AQSE910	AQX-1/16, 5/64, 3/32, 1/8, 5/32, 3/16, 1/4, 5/16, 3/8	395	5	12,080

- Plastic Holder
- Blister pack 265 × 90 × 30mm

**inch**



AQSE910

TOOL SETS

SPANNERS

STRIKING FACE WRENCHES

HOOK SPANNERS

DX2000 TOOLS  
HEXAGON KEY WRENCHES

HEXAGON KEY WRENCHES

TORQUE WRENCHES

CROWFOOT WRENCHES

SOCKETS

OTHER TOOLS

# Ballpoint Hexagon Key Wrenches

## Different Colors For Each Size / Long type

**Auroline®**

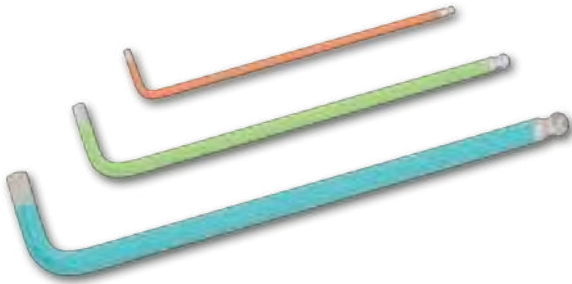

Code	Ø mm	L mm	ℓ mm	Weight g		Price ¥
AQU0150	1.5	90	14	1.4	-	820
AQU0200	2	100	16	3	-	820
AQU0250	2.5	112	18	5.2	-	840
AQU0300	3	126	20	8.8	-	840
AQU0400	4	142	23	16	-	930
AQU0500	5	160	28	30	-	1,100
AQU0600	6	180	32	50	-	1,440
AQU0800	8	200	36	100	-	1,840
AQU1000	10	224	40	178	-	2,510

- Special Alloy Steel ( ~ 0600 )
- Alloy Steel ( 0800 ~ )
- Nickel Chrome Plating
- Baking Finish

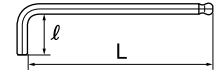

AQU5710

**7Pcs.**

1.5 mm 2 mm 2.5 mm 3 mm 4 mm 5 mm 6 mm

Code	Ø mm	Weight g		Price ¥
AQU5710	AQU-1.5, 2, 2.5, 3, 4, 5, 6	140	10	7,100

- Plastic Holder
- Blister pack 240 × 75 × 15mm



AQU5910

**9Pcs.**

1.5 mm 2 mm 2.5 mm 3 mm 4 mm 5 mm 6 mm 8 mm 10 mm

Code	Ø mm	Weight g		Price ¥
AQU5910	AQU-1.5, 2, 2.5, 3, 4, 5, 6, 8, 10	420	5	11,500

- Plastic Holder
- Blister pack 290 × 90 × 25mm

TOOL SETS  
SPANNERS  
STRIKING FACE WRENCHES  
HOOK SPANNERS  
DX2000 TOOLS  
HEXAGON KEY WRENCHES  
HEXAGON KEY WRENCHES  
TORQUE WRENCHES  
CROWFOOT WRENCHES  
SOCKETS  
OTHER TOOLS

# Ballpoint Hexagon Key Wrenches

## Short type

Code	○ mm	L mm	ℓ mm	Weight g		Price ¥
AZ0150	1.5	50	14	1	10	670
AZ0200	2	56	16	1.8	10	670
AZ0250	2.5	63	18	3.2	10	690
AZ0300	3	71	20	5.4	10	690
AZ0400	4	80	22	10	10	710
AZ0500	5	90	25	18	10	800
AZ0600	6	100	28	30	10	950
AZ0800	8	112	32	62	10	1,260
AZ1000	10	125	36	110	10	1,650
AZ1200	12	140	40	176	3	3,150
AZ1400	14	160	45	280	3	3,570

- Special Alloy Steel ( ~ 0600)
- Alloy Steel (0800 ~ )
- Nickel Chrome Plating
- Blister pack

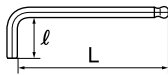

**7Pcs.**

1.5 mm 2 mm 2.5 mm 3 mm 4 mm 5 mm 6 mm

Code	○ mm	Weight g		Price ¥
AZS0710	AZ-1.5, 2, 2.5, 3, 4, 5, 6	100	10	5,400

- Plastic Holder
- Blister pack 165 × 75 × 15mm



AZS0710

**9Pcs.**

1.5 mm 2 mm 2.5 mm 3 mm 4 mm 5 mm 6 mm 8 mm 10 mm

Code	○ mm	Weight g		Price ¥
AZS0910	AZ-1.5, 2, 2.5, 3, 4, 5, 6, 8, 10	280	5	8,500

- Plastic Holder
- Blister pack 190 × 90 × 30mm



AZS0910

TOOL SETS

SPANNERS

STRIKING FACE WRENCHES

HOOK SPANNERS

HEXAGON KEY WRENCHES

HEXAGON KEY WRENCHES

TORQUE WRENCHES

CROWFOOT WRENCHES

SOCKETS

OTHER TOOLS

# Ballpoint Hexagon Key Wrenches

## Different Colors For Each Size / Short type

**Auroline®**

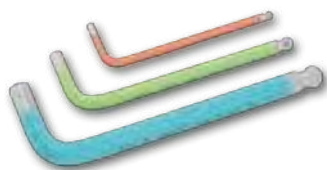

Code	Ø mm	L mm	ℓ mm	Weight g		Price ¥
AZU0150	1.5	50	14	1	-	770
AZU0200	2	56	16	1.8	-	770
AZU0250	2.5	63	18	3.2	-	790
AZU0300	3	71	20	5.4	-	790
AZU0400	4	80	22	10	-	820
AZU0500	5	90	25	18	-	930
AZU0600	6	100	28	30	-	1,100
AZU0800	8	112	32	62	-	1,450
AZU1000	10	125	36	110	-	1,910

- Special Alloy Steel ( ~ 0600 )
- Alloy Steel (0800 ~ )
- Nickel Chrome Plating
- Baking Finish

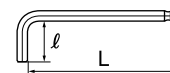

AZUS710

**7Pcs.**

1.5 mm 2 mm 2.5 mm 3 mm 4 mm 5 mm 6 mm

Code	Ø mm	Weight g		Price ¥
AZUS710	AZU-1.5, 2, 2.5, 3, 4, 5, 6	100	10	5,900

- Plastic Holder
- Blister pack 165 × 75 × 15mm



AZUS910

**9Pcs.**

1.5 mm 2 mm 2.5 mm 3 mm 4 mm 5 mm 6 mm 8 mm 10 mm

Code	Ø mm	Weight g		Price ¥
AZUS910	AZU-1.5, 2, 2.5, 3, 4, 5, 6, 8, 10	280	5	9,200

- Plastic Holder
- Blister pack 190 × 90 × 25mm

TOOL SETS

SPANNERS

STRIKING FACE WRENCHES

HOOK SPANNERS

DX2000 TOOLS  
HEXAGON KEY WRENCHES

HEXAGON KEY WRENCHES

TORQUE WRENCHES

CROWFOOT WRENCHES

SOCKETS

OTHER TOOLS

# Hexagon Key Wrenches

## Long type

Code	○ mm	L mm	ℓ mm	Weight g		Price ¥
AY0150	1.5	90	14	1.4	10	380
AY0200	2	100	16	3	10	380
AY0250	2.5	112	18	5.2	10	400
AY0300	3	126	20	8.8	10	470
AY0400	4	142	23	16	10	550
AY0500	5	160	28	30	10	760
AY0600	6	180	32	50	10	1,170
AY0800	8	200	36	100	10	1,510
AY1000	10	224	40	178	10	2,190
AY1200	12	250	45	290	3	2,840
AY1400	14	280	56	448	3	3,860
AY1700	17	320	63	754	4	4,900
AY1900	19	360	70	1,055	4	7,400

- Special Alloy Steel ( ~ 0600)
- Alloy Steel (0800 ~ )
- Nickel Chrome Plating
- Blister pack (0150 ~ 1400)



**7Pcs.**

1.5 mm 2 mm 2.5 mm 3 mm 4 mm 5 mm 6 mm

Code	○ mm	Weight g		Price ¥
AYS0710	AY-1.5, 2, 2.5, 3, 4, 5, 6	150	10	3,960

- Plastic Holder
- Blister pack 240 × 75 × 15mm



AYS0710

**9Pcs.**

1.5 mm 2 mm 2.5 mm 3 mm 4 mm 5 mm 6 mm 8 mm 10 mm

Code	○ mm	Weight g		Price ¥
AYS0910	AY-1.5, 2, 2.5, 3, 4, 5, 6, 8, 10	450	5	7,800

- Plastic Holder
- Blister pack 290 × 90 × 30mm



AYS0910

TOOL SETS

SPANNERS

STRIKING FACE WRENCHES

HOOK SPANNERS

DX2000 TOOLS  
HEXAGON KEY WRENCHES

HEXAGON KEY WRENCHES

TORQUE WRENCHES

CROWFOOT WRENCHES

SOCKETS

OTHER TOOLS

# Hexagon Key Wrenches

## Short type



Code	⌀ mm	L mm	ℓ mm	Weight g		Price ¥
AX0150	1.5	50	14	1	10	310
AX0200	2	56	16	1.8	10	310
AX0250	2.5	63	18	3.2	10	320
AX0300	3	71	20	5.4	10	330
AX0400	4	80	22	10	10	350
AX0500	5	90	25	18	10	420
AX0600	6	100	28	30	10	580
AX0800	8	112	32	62	10	830
AX1000	10	125	36	110	10	1,330
AX1200	12	140	40	176	3	2,270
AX1400	14	160	45	280	3	2,910

- Special Alloy Steel ( ~ 0600 )
- Alloy Steel (0800 ~ )
- Nickel Chrome Plating
- Blister pack



AXS0710

**7Pcs.**

1.5 mm 2 mm 2.5 mm 3 mm 4 mm 5 mm 6 mm

Code	⌀ mm	Weight g		Price ¥
AXS0710	AX-1.5, 2, 2.5, 3, 4, 5, 6	100	10	2,820

- Plastic Holder
- Blister pack 165 × 75 × 15mm



AXS0910

**9Pcs.**

1.5 mm 2 mm 2.5 mm 3 mm 4 mm 5 mm 6 mm 8 mm 10 mm

Code	⌀ mm	Weight g		Price ¥
AXS0910	AX-1.5, 2, 2.5, 3, 4, 5, 6, 8, 10	290	5	4,760

- Plastic Holder
- Blister pack 190 × 90 × 30mm



## Double-Ended

This product only requires only 30 degrees turning angle (half of normal space), as both ends are bent twisted 90 degrees opposite angle. Please use the both end interchangeably to work continuously.

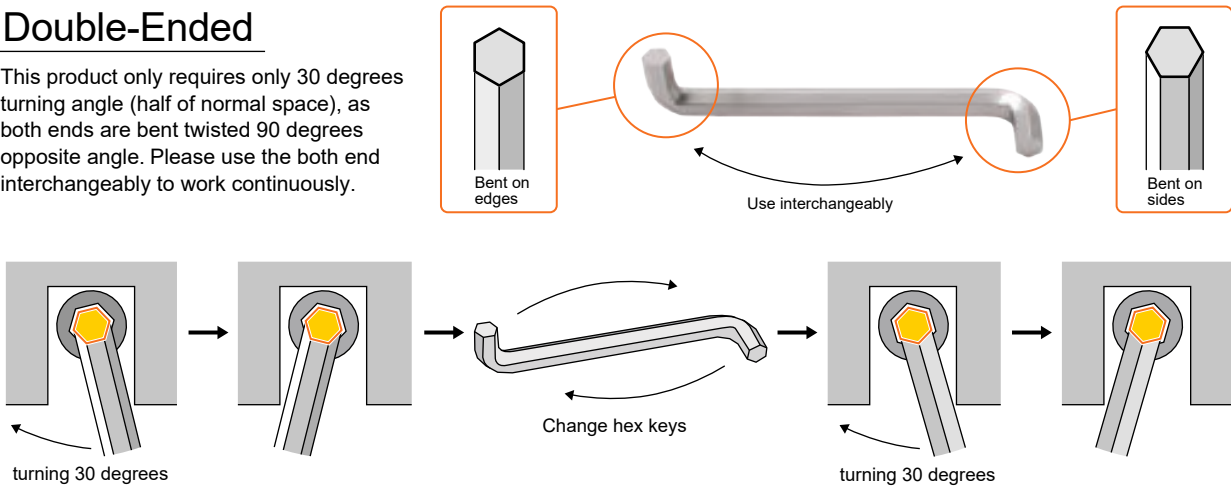

## Long type

Code	Hex Key Size (mm)	L (mm)	ℓ (mm)	Weight (g)	Box Qty	Price (¥)
DY0150	1.5	90	6	1.5	10	1,010
DY0200	2	100	6.5	2.5	10	1,010
DY0250	2.5	112	8	5	10	1,010
DY0300	3	126	10	8	10	1,010
DY0400	4	142	12	17	10	1,090
DY0500	5	160	14	30	10	1,250
DY0600	6	180	18	57	10	1,600
DY0800	8	200	23	100	10	2,090
DY1000	10	224	27.5	183	10	3,000

- Special Alloy Steel ( ~ 0300)
- Alloy Steel (0400 ~ )
- Nickel Chrome Plating
- Blister pack

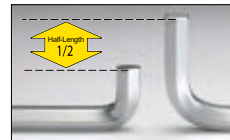
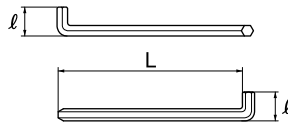

Our hex key ends are shorter than existing products (approximately half of the length), and it ensures space-constrained work.

**9Pcs.**

1.5 mm 2 mm 2.5 mm 3 mm 4 mm 5 mm 6 mm 8 mm 10 mm

Code	Hex Key Size (mm)	Weight (g)	Box Qty	Price (¥)
DYS0910	DY-1.5, 2, 2.5, 3, 4, 5, 6, 8, 10	400	5	10,800

- Plastic Holder
- Blister pack 290 × 90 × 50mm



# Daxkey Wrench Double-Ended Short type



Code	Ø mm	L mm	ℓ mm	Weight g		Price ¥
DZ0150	1.5	50	6	0.8	10	950
DZ0200	2	56	6.5	1.7	10	950
DZ0250	2.5	63	8	3	10	950
DZ0300	3	71	10	5	10	950
DZ0400	4	80	12	10	10	1,040
DZ0500	5	90	14	18	10	1,190
DZ0600	6	100	18	30	10	1,510
DZ0800	8	112	23	62	10	1,980
DZ1000	10	125	27.5	105	10	2,840

- Special Alloy Steel ( ~ 0300)
- Alloy Steel (0400 ~ )
- Nickel Chrome Plating
- Blister pack

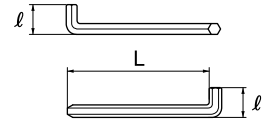

**9Pcs.**

1.5 mm 2 mm 2.5 mm 3 mm 4 mm 5 mm 6 mm 8 mm 10 mm

Code	Ø mm	Weight g		Price ¥
DZS0910	DZ-1.5, 2, 2.5, 3, 4, 5, 6, 8, 10	270	5	9,300

- Plastic Holder
- Blister pack 190 × 90 × 50mm

TOOL SETS

SPANNERS

STRIKING FACE WRENCHES

HOOK SPANNERS

DX2000 TOOLS  
HEXAGON KEY WRENCHES

HEXAGON KEY WRENCHES

TORQUE WRENCHES

CROWFOOT WRENCHES

SOCKETS

OTHER TOOLS

## Bent On Edges

Our products are bent on its edges; existing products are usually bent on its sides. Designed to be used continuously at 30 degrees rotation angle using interchangeably to an existing hex key.

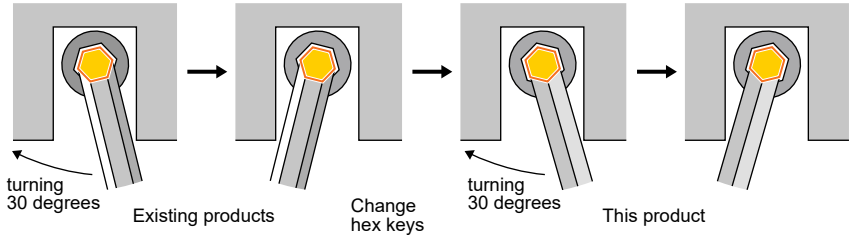
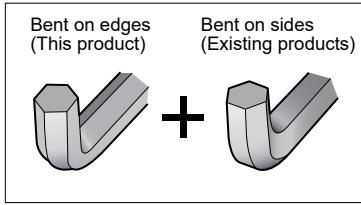

## Half-Length Hex Key Ends

Our hex key ends are shorter than existing products (approximately half of the length), and it ensures space-constrained work.

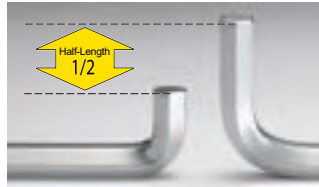

This product

Existing products

Make a huge difference in working in a narrow space

## Ballpoint / Long type

without Catcher Ball

Code	Ø mm	L mm	ℓ mm	Weight g	Box	Price ¥
DV0150	1.5	90	6	1.3	10	930
DV0200	2	100	6.5	2.7	10	930
DV0250	2.5	112	8	5	10	950

with Catcher Ball

Code	Ø mm	L mm	ℓ mm	Weight g	Box	Price ¥
DV0300	3	126	10	8	10	1,040
DV0400	4	142	12	16	10	1,100
DV0500	5	160	14	25	10	1,310
DV0600	6	180	18	48	10	1,670
DV0800	8	200	23	90	10	2,090
DV1000	10	224	27.5	160	10	2,990
DV1200	12	250	34	270	5	4,680
DV1400	14	280	41	410	5	5,900
DV1700	17	320	48	690	5	10,100
DV1900	19	360	53	970	5	13,300

- Special Alloy Steel ( ~ 0300)
- Alloy Steel (0400 ~ )
- Nickel Chrome Plating
- Blister pack (0150 ~ 1000)



**9Pcs.**

1.5 mm	2 mm	2.5 mm	3 mm	4 mm	5 mm	6 mm	8 mm	10 mm
without Catcher Ball			with Catcher Ball					

Code	Ø mm	Weight g	Box	Price ¥
DVS0910	DV-1.5, 2, 2.5, 3, 4, 5, 6, 8, 10	395	5	11,700

- Plastic Holder
- Blister pack 290 × 90 × 50mm



# Daxkey Wrench Bent On Edges

## Ballpoint / Short type



### without Catcher Ball

Code	Ø mm	L mm	ℓ mm	Weight g		Price ¥
DW0150	1.5	50	6	0.7	10	800
DW0200	2	56	6.5	1.6	10	800
DW0250	2.5	63	8	2.8	10	810

### with Catcher Ball

Code	Ø mm	L mm	ℓ mm	Weight g		Price ¥
DW0300	3	71	10	4.6	10	920
DW0400	4	80	12	9.5	10	950
DW0500	5	90	14	16	10	1,030
DW0600	6	100	18	26	10	1,180
DW0800	8	112	23	55	10	1,480
DW1000	10	125	27.5	95	10	1,970

- Special Alloy Steel ( ~ 0300 )
- Alloy Steel (0400 ~ )
- Nickel Chrome Plating
- Blister pack



**9Pcs.**

1.5 mm	2 mm	2.5 mm	3 mm	4 mm	5 mm	6 mm	8 mm	10 mm
without Catcher Ball				with Catcher Ball				

Code	Ø mm	Weight g		Price ¥
DWS0910	DW-1.5, 2, 2.5, 3, 4, 5, 6, 8, 10	245	5	10,000

- Plastic Holder
- Blister pack 190 × 90 × 50mm

TOOL SETS

SPANNERS

STRIKING FACE WRENCHES

HOOK SPANNERS

**DX2000 TOOLS**  
HEXAGON KEY WRENCHES

HEXAGON KEY WRENCHES

TORQUE WRENCHES

CROWFOOT WRENCHES

SOCKETS

OTHER TOOLS

## Catcher Ball

A spring suspension and a steel ball implanted by a high-precision processing technology holds the bolt securely. The bolt is firmly secured and does not need to be held by a hand before or after tightening, or during work in an inaccessible place.

(It corresponds to 3mm from 10mm)

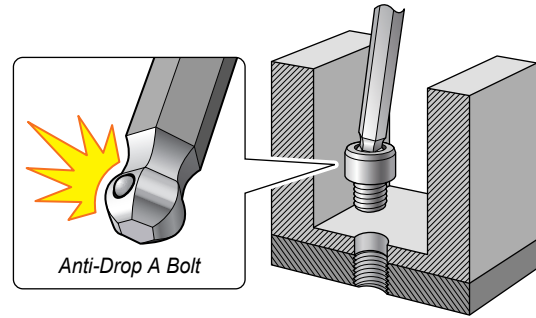

## Ballpoint / Long type

Code	Ø mm	L mm	ℓ mm	Weight g	Box	Price ¥
AQK0300	3	126	20	9	10	900
AQK0400	4	142	23	16	10	970
AQK0500	5	160	28	30	10	1,150
AQK0600	6	180	32	50	10	1,510
AQK0800	8	200	36	100	10	1,920
AQK1000	10	224	40	180	10	2,630

- Special Alloy Steel ( ~ 0600 )
- Alloy Steel (0800 ~ )
- Nickel Chrome Plating
- Blister pack

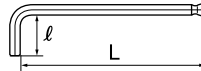

Code	Ø inch	L mm	ℓ mm	Weight g	Box	Price ¥
AQKX108	1/8	126	20	10	10	970
AQKX532	5/32	142	23	17	10	1,090
AQKX316	3/16	160	28	29	10	1,270
AQKX104	1/4	180	32	57	10	1,630
AQKX516	5/16	200	36	98	10	2,040
AQKX308	3/8	224	40	160	10	3,020

- Special Alloy Steel ( ~ 316 )
- Alloy Steel (104 ~ )
- Nickel Chrome Plating



inch



# Ballpoint / Long type



AQKS710

<b>7Pcs.</b>						
1.5 mm	2 mm	2.5 mm	3 mm	4 mm	5 mm	6 mm
without Catcher Ball			with Catcher Ball			

Code	mm	Weight g	Box	Price ¥
AQKS710	AQ-1.5, 2, 2.5 AQK-3, 4, 5, 6	130	10	7,300

- Plastic Holder
- Blister pack 240 × 75 × 15mm



AQKS910

<b>9Pcs.</b>								
1.5 mm	2 mm	2.5 mm	3 mm	4 mm	5 mm	6 mm	8 mm	10 mm
without Catcher Ball			with Catcher Ball					

Code	mm	Weight g	Box	Price ¥
AQKS910	AQ-1.5, 2, 2.5 AQK-3, 4, 5, 6, 8, 10	420	5	12,000

- Plastic Holder
- Blister pack 290 × 90 × 30mm

inch



<b>9Pcs.</b>								
1/16	5/64	3/32	1/8	5/32	3/16	1/4	5/16	3/8
without Catcher Ball			with Catcher Ball					

Code	inch	Weight g	Box	Price ¥
AQKSE91	AQX-1/16, 5/64, 3/32 AQKX-1/8, 5/32, 3/16, 1/4, 5/16, 3/8	400	5	13,300

- Plastic Holder
- Blister pack 265 × 90 × 30mm

**Auroline**

NEW



Code	mm	L mm	l mm	Weight g	Box	Price ¥
AQKU030	3	126	20	8.8	-	950
AQKU040	4	142	23	16	-	1,020
AQKU050	5	160	28	30	-	1,210
AQKU060	6	180	32	50	-	1,590
AQKU080	8	200	36	100	-	2,020
AQKU100	10	224	40	178	-	2,770

- Special Alloy Steel ( ~ 060)
- Alloy Steel (080 ~ )
- Nickel Chrome Plating
- Baking Finish

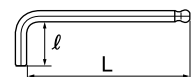

**Auroline**

NEW



<b>9Pcs.</b>								
1.5 mm	2 mm	2.5 mm	3 mm	4 mm	5 mm	6 mm	8 mm	10 mm
without Catcher Ball			with Catcher Ball					

Code	mm	Weight g	Box	Price ¥
AQKUS91	AQU-1.5, 2, 2.5 AQKU-3, 4, 5, 6, 8, 10	420	5	12,400

- Plastic Holder
- Blister pack 290 × 90 × 25mm



# Catcher® Wrench Catcher Ball

## Ballpoint / Short type

Code	○ mm	L mm	ℓ mm	Weight g		Price ¥
AZK0300	3	71	20	5.5	10	770
AZK0400	4	80	22	10	10	790
AZK0500	5	90	25	18	10	890
AZK0600	6	100	28	30	10	1,050
AZK0800	8	112	32	62	10	1,400
AZK1000	10	125	36	110	10	1,850

- Special Alloy Steel ( ~ 0600 )
- Alloy Steel (0800 ~ )
- Nickel Chrome Plating

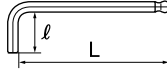

9Pcs.	1.5 mm	2 mm	2.5 mm	3 mm	4 mm	5 mm	6 mm	8 mm	10 mm
	without Catcher Ball	with Catcher Ball							

Code	○ mm	Weight g		Price ¥
AZKS910	AZ-1.5, 2, 2.5 AZK-3, 4, 5, 6, 8, 10	280	5	9,200

- Plastic Holder
- Blister pack 190 × 90 × 30mm



## Long type

Code	○ mm	L mm	ℓ mm	Weight g		Price ¥
AYK0300	3	126	20	9	10	520
AYK0400	4	142	23	16	10	600
AYK0500	5	160	28	30	10	800
AYK0600	6	180	32	50	10	1,210
AYK0800	8	200	36	100	10	1,570
AYK1000	10	224	40	180	10	2,280

- Special Alloy Steel ( ~ 0600 )
- Alloy Steel (0800 ~ )
- Nickel Chrome Plating
- Blister pack

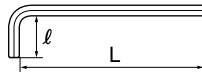

9Pcs.	1.5 mm	2 mm	2.5 mm	3 mm	4 mm	5 mm	6 mm	8 mm	10 mm
	without Catcher Ball	with Catcher Ball							

Code	○ mm	Weight g		Price ¥
AYKS910	AY-1.5, 2, 2.5 AYK-3, 4, 5, 6, 8, 10	410	5	8,400

- Plastic Holder
- Blister pack 290 × 90 × 30mm



TOOL SETS

SPANNERS

STRIKING FACE WRENCHES

HOOK SPANNERS

HEXAGON KEY WRENCHES

HEXAGON KEY WRENCHES

TORQUE WRENCHES









CROWFOOT WRENCHES

SOCKETS

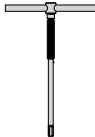

OTHER TOOLS

# Hexagon Key Wrenches

## [Metric]

									
		AW	AL	EX	AP	ARS	ANS	VTH	ATL
Length	Short	●				●			
	Long		●	●					
	Standard				●				
Functions	Ball Point				●				
	Catcher Ball								
Shape	Set On Ring					●			
	Convenient Holder						●		
	T-Handled							●	●
	Separate Type							●	
Size $\text{mm}$	0.71			●					
	0.89			●					
	1.27			●					
	1.5	●	●		●				
	2	●	●		●				
	2.5	●	●		●				●
	3	●	●		●			●	●
	4	●	●		●			●	●
	5	●	●		●			●	●
	6	●	●		●			●	●
	7	●							
	8	●	●		●			●	
	10	●	●		●				
	12	●	●		●				
	14	●	●		●				
	16	●							
	17	●	●		●				
	19	●	●		●				
	21	●							
	22	●			●				
	24	●			●				
26	●								
27	●			●					
32	●			●					
36	●			●					
41	●								
46	●								
50	●								

## [Inch]

				
		AWX	ARSE	ANS
Short		●		
Set On Ring			●	
Convenient Holder				●
1/16		●		
5/64		●		
3/32		●		
1/8		●		
5/32		●		
3/16		●		
7/32		●		
1/4		●		
5/16		●		
3/8		●		
7/16		●		
1/2		●		

## [Hexlobe]

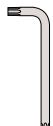
		
		ATX
T10H		●
T15H		●
T20H		●
T25H		●
T27H		●
T30H		●
T40H		●

# Hexagon Key Wrench

## Short type

Code	⌀ mm	L mm	ℓ mm	Weight g		Price ¥
AW0150	1.5	45	14	0.8	100	72
AW0200	2	50	16	1.8	100	72
AW0250	2.5	56	18	3	100	72
AW0300	3	63	20	5	100	72
AW0400	4	72	23	10	100	78
AW0500	5	80	28	18	100	92
AW0600	6	90	32	28	100	120
AW0700	7	95	34	42	50	160
AW0800	8	100	36	60	50	190
AW1000	10	112	40	105	50	300
AW1200	12	125	45	170	30	480
AW1400	14	140	56	266	10	700
AW1600	16	157	63	400	10	1,630
AW1700	17	160	63	446	10	1,050
AW1900	19	180	70	624	10	1,960
AW2100	21	198	75	866	6	3,070
AW2200	22	200	80	950	6	3,890
AW2400	24	224	90	1,253	-	4,220
AW2600	26	250	100	1,636	-	6,200
AW2700	27	250	100	1,764	-	6,600
AW3200	32	315	125	3,120	-	9,800
AW3600	36	355	140	4,440	-	13,000
AW4100	41	400	160	6,500	-	22,700
AW4600	46	440	180	9,220	-	29,200
AW5000	50	480	200	11,930	-	35,600

- Black Oxide Finish ( ~ 1000 )
- Cathodic Electrodeposition ( 1200 ~ )



Code	⌀ inch	L mm	ℓ mm	Weight g		Price ¥
AWX0116	1/16	45	14	1	-	300
AWX0564	5/64	50	16	2	-	300
AWX0332	3/32	56	18	3	-	300
AWX0108	1/8	63	20	6	-	300
AWX0532	5/32	70	23	11	-	300
AWX0316	3/16	80	28	18	-	300
AWX0732	7/32	85	30	25	-	420
AWX0104	1/4	90	32	35	-	420
AWX0516	5/16	100	36	62	-	560
AWX0308	3/8	112	40	101	-	710
AWX0716	7/16	119	42	135	-	1,130
AWX0102	1/2	125	45	200	-	1,130

- Black Oxide Finish ( ~ 0104 )
- Cathodic Electrodeposition ( 0516 ~ )

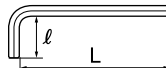

inch



TOOL SETS

SPANNERS

STRIKING FACE WRENCHES

HOOK SPANNERS

DX2000 TOOLS  
HEXAGON KEY WRENCHES

HEXAGON KEY WRENCHES

TORQUE WRENCHES

CROWFOOT WRENCHES

SOCKETS

OTHER TOOLS

# Hexagon Key Wrench

## Short type

**7Pcs.**

1.5 mm 2 mm 2.5 mm 3 mm 4 mm 5 mm 6 mm

Code	mm	Weight g	Box	Price ¥
AWS0770	AW-1.5, 2, 2.5, 3, 4, 5, 6	100	10	1,130

- Plastic Holder
- Blister pack 165 × 75 × 18mm



AWS0770

**8Pcs.**

2.5 mm 3 mm 4 mm 5 mm 6 mm 8 mm 10 mm 12 mm

Code	mm	Weight g	Box	Price ¥
AWS0810	AW-2.5, 3, 4, 5, 6, 8, 10, 12	420	10	1,700

- Tool Roll 200 × 120mm



AWS0810

**8Pcs.**

3 mm 4 mm 5 mm 6 mm 8 mm 10 mm 12 mm 14 mm

Code	mm	Weight g	Box	Price ¥
AWS0820	AW-3, 4, 5, 6, 8, 10, 12, 14	800	5	2,620

- Tool Roll 170 × 225mm



AWS0820

TOOL SETS

SPANNERS

STRIKING FACE WRENCHES

HOOK SPANNERS

DX2000 TOOLS  
HEXAGON KEY WRENCHES

HEXAGON KEY WRENCHES

TORQUE WRENCHES

CROWFOOT WRENCHES

SOCKETS

OTHER TOOLS

# Hexagon Key Wrench

## Short type

**8Pcs.**

1.5 mm 2 mm 2.5 mm 3 mm 4 mm 5 mm 6 mm 8 mm

Code	mm	Weight g	Box	Price ¥
AWS0880	AW-1.5, 2, 2.5, 3, 4, 5, 6, 8	152	5	1,250

- Plastic Holder
- Blister pack 165 × 90 × 18mm



AWS0880

**9Pcs.**

1.5 mm 2 mm 2.5 mm 3 mm 4 mm 5 mm 6 mm 8 mm 10 mm

Code	mm	Weight g	Box	Price ¥
AWS0990	AW-1.5, 2, 2.5, 3, 4, 5, 6, 8, 10	280	10	1,580

- Plastic Holder
- Blister pack 190 × 90 × 27mm



AWS0990

**8Pcs.**

1/8 3/16 7/32 1/4 5/16 3/8 7/16 1/2

Code	inch	Weight g	Box	Price ¥
AWS0830	AWX-1/8, 3/16, 7/32, 1/4, 5/16, 3/8, 7/16, 1/2	560	10	2,400

- Tool Roll 200 × 120mm

inch



AWS0830

TOOL SETS

SPANNERS

STRIKING FACE WRENCHES

HOOK SPANNERS

DX2000 TOOLS

HEXAGON KEY WRENCHES

TORQUE WRENCHES

CROWFOOT WRENCHES

SOCKETS

OTHER TOOLS

# Hexagon Key Wrench

## Long type

Code	mm	L mm	ℓ mm	Weight g	Box	Price ¥
AL0150	1.5	90	14	1.4	10	160
AL0200	2	100	16	3	10	160
AL0250	2.5	112	18	5.2	10	160
AL0300	3	126	20	8.8	10	170
AL0400	4	142	23	16	10	310
AL0500	5	160	28	32	10	400
AL0600	6	180	32	50	10	500
AL0800	8	200	36	100	10	710
AL1000	10	224	40	178	10	1,000
AL1200	12	250	45	290	4	1,570
AL1400	14	280	56	448	4	2,350
AL1700	17	320	63	754	4	2,940
AL1900	19	360	70	1,055	4	3,700

- Black Oxide Finish ( ~ 1000)
- Cathodic Electrodeposition (1200 ~ )

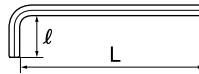

TOOL SETS  
SPANNERS  
STRIKING FACE WRENCHES  
HOOK SPANNERS  
DX2000 TOOLS  
HEXAGON KEY WRENCHES  
HEXAGON KEY WRENCHES  
TORQUE WRENCHES  
CROWFOOT WRENCHES  
SOCKETS  
OTHER TOOLS

**7Pcs.**

1.5 mm 2 mm 2.5 mm 3 mm 4 mm 5 mm 6 mm

Code	mm	Weight g	Box	Price ¥
ALS0770	AL-1.5, 2, 2.5, 3, 4, 5, 6	150	10	2,070

- Plastic Holder
- Blister pack 240 × 75 × 18mm



ALS0770

**7Pcs.**

2.5 mm 3 mm 4 mm 5 mm 6 mm 8 mm 10 mm

Code	mm	Weight g	Box	Price ¥
ALS0790	AL-2.5, 3, 4, 5, 6, 8, 10	425	5	3,310

- Plastic Holder
- Blister pack 290 × 90 × 27mm



ALS0790

**9Pcs.**

1.5 mm 2 mm 2.5 mm 3 mm 4 mm 5 mm 6 mm 8 mm 10 mm

Code	mm	Weight g	Box	Price ¥
ALS0990	AL-1.5, 2, 2.5, 3, 4, 5, 6, 8, 10	450	5	3,660

- Plastic Holder
- Blister pack 290 × 90 × 27mm



ALS0990



# Hexagon Key Wrench

## Micro / Long type

Code	○ mm	L mm	ℓ mm	Weight g		Price ¥
EX0710	0.71	53	10.5	0.2	100	470
EX0890	0.89	60.5	12	0.4	100	470
EX1270	1.27	70	14	0.9	100	470

- Parkerizing
- Vinyl Pack



**6Pcs.**

0.71 mm 0.89 mm 1.27 mm 1.5 mm 2 mm 2.5 mm

Code	○ mm	Weight g		Price ¥
MELS610	EX-0.71, 0.89, 1.27 AL-1.5, 2, 2.5	26	—	1,190

- Tool Roll 180 × 100mm



TOOL SETS

SPANNERS

STRIKING FACE WRENCHES

HOOK SPANNERS

DX2000 TOOLS  
HEXAGON KEY WRENCHES

HEXAGON KEY WRENCHES

TORQUE WRENCHES

CROWFOOT WRENCHES

SOCKETS

OTHER TOOLS

# Ballpoint Hexagon Key Wrench

## Standard type

Code	○ mm	L mm	ℓ mm	Weight g		Price ¥
AP0150	1.5	70	14	1.2	50	470
AP0200	2	75	16	2.4	50	470
AP0250	2.5	84	18	4	50	470
AP0300	3	95	20	6	50	490
AP0400	4	105	23	14	50	580
AP0500	5	120	28	24	10	630
AP0600	6	135	32	40	10	810
AP0800	8	150	36	80	10	1,010
AP1000	10	170	40	140	10	1,130
AP1200	12	185	45	220	10	1,930
AP1400	14	207	56	345	5	2,640
AP1700	17	220	63	550	5	3,390
AP1900	19	225	70	730	5	3,970
AP2200	22	246	80	1,060	-	5,460
AP2400	24	282	90	1,420	-	-
AP2700	27	325	100	2,100	-	-
AP3200	32	370	125	3,400	-	-
AP3600	36	455	140	5,200	-	-

- Black Oxide Finish ( ~ 1000 )
- Cathodic Electrodeposition ( 1200 ~ )
- Special Order ( 2400 ~ )

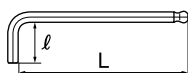

**7Pcs.**

2.5 mm 3 mm 4 mm 5 mm 6 mm 8 mm 10 mm

Code	○ mm	Weight g		Price ¥
APS0710	AP-2.5, 3, 4, 5, 6, 8, 10	340	5	5,670

- Plastic Holder
- Blister pack 240 × 85 × 27mm



APS0710

**9Pcs.**

1.5 mm 2 mm 2.5 mm 3 mm 4 mm 5 mm 6 mm 8 mm 10 mm

Code	○ mm	Weight g		Price ¥
APS0990	AP-1.5, 2, 2.5, 3, 4, 5, 6, 8, 10	360	5	6,510

- Plastic Holder
- Blister pack 240 × 85 × 27mm



APS0990

TOOL SETS

SPANNERS

STRIKING FACE WRENCHES

HOOK SPANNERS

DX2000 TOOLS  
HEXAGON KEY WRENCHES

HEXAGON KEY WRENCHES

TORQUE WRENCHES

CROWFOOT WRENCHES

SOCKETS

OTHER TOOLS

# Set On Ring

## Short type

**7Pcs.**

2 mm 2.5 mm 3 mm 4 mm 5 mm 6 mm 8 mm

Code	mm	Weight g	Box	Price ¥
ARS0710	2, 2.5, 3, 4, 5, 6, 8	160	10	1,080

- Black Oxide Finish
- Blister pack 190 × 80mm



ARS0710

**8Pcs.**

2 mm 2.5 mm 3 mm 4 mm 5 mm 6 mm 8 mm 10 mm

Code	mm	Weight g	Box	Price ¥
ARS0810	2, 2.5, 3, 4, 5, 6, 8, 10	270	10	1,310

- Black Oxide Finish
- Blister pack 190 × 80mm



ARS0810

**8Pcs.**

1.5 mm 2 mm 2.5 mm 3 mm 4 mm 5 mm 5.5 mm 6 mm

Code	mm	Weight g	Box	Price ¥
ARS0820	1.5, 2, 2.5, 3, 4, 5, 5.5, 6	120	10	1,020

- Black Oxide Finish
- Blister pack 190 × 80mm



ARS0820

**10Pcs.**

1.5 mm 2 mm 2.5 mm 3 mm 4 mm 5 mm 5.5 mm 6 mm 8 mm 10 mm

Code	mm	Weight g	Box	Price ¥
ARS1110	1.5, 2, 2.5, 3, 4, 5, 5.5, 6, 8, 10	290	10	1,400

- Black Oxide Finish
- Blister pack 190 × 80mm



ARS1110

**8Pcs.**

1/16 5/64 3/32 1/8 5/32 3/16 7/32 1/4

Code	inch	Weight g	Box	Price ¥
ARSE820	1/16, 5/64, 3/32, 1/8, 5/32, 3/16, 7/32, 1/4	120	10	1,160

- Black Oxide Finish
- Blister pack 185 × 80mm

inch



ARSE820

**10Pcs.**

1/16 5/64 3/32 1/8 5/32 3/16 7/32 1/4 5/16 3/8

Code	inch	Weight g	Box	Price ¥
ARSE110	1/16, 5/64, 3/32, 1/8, 5/32, 3/16, 7/32, 1/4, 5/16, 3/8	290	10	1,600

- Black Oxide Finish
- Blister pack 185 × 80mm

inch



ARSE110

TOOL SETS

SPANNERS

STRIKING FACE WRENCHES

HOOK SPANNERS

DX2000 TOOLS  
HEXAGON KEY WRENCHES

HEXAGON KEY WRENCHES

TORQUE WRENCHES

GROUND WRENCHES

SOCKETS

OTHER TOOLS

# Convenient Holder

## Short type

**6Pcs.**

2.5 mm 3 mm 4 mm 5 mm 6 mm 8 mm

Code	mm	Weight g	Box	Price ¥
ANS0610	2.5, 3, 4, 5, 6, 8	245	10	2,640

- Black Oxide Finish
- Blister pack 190 × 65mm



ANS0610

**7Pcs.**

1.5 mm 2 mm 2.5 mm 3 mm 4 mm 5 mm 6 mm

Code	mm	Weight g	Box	Price ¥
ANS0710	1.5, 2, 2.5, 3, 4, 5, 6	145	10	2,540

- Black Oxide Finish
- Blister pack 140 × 50mm



ANS0710

**7Pcs.**

1/16 5/64 3/32 1/8 5/32 3/16 7/32

Code	inch	Weight g	Box	Price ¥
ANS0730	1/16, 5/64, 3/32, 1/8, 5/32, 3/16, 7/32	135	10	3,170

- Black Oxide Finish
- Blister pack 140 × 50mm

inch



ANS0730

TOOL SETS

SPANNERS

STRIKING FACE WRENCHES

HOOK SPANNERS

DX2000 TOOLS  
HEXAGON KEY WRENCHES

HEXAGON KEY WRENCHES

TORQUE WRENCHES

CROWFOOT WRENCHES

SOCKETS

OTHER TOOLS

## T-Handled Separate type / Metric

Code	○ mm	L <sub>1</sub> mm	D <sub>1</sub> mm	L <sub>2</sub> mm	D <sub>2</sub> mm	L <sub>3</sub> mm	Weight g		Price ¥
VTH0300	3	125	9	120	6.4	210	35	10	3,180
VTH0400	4	180	11	120	8.4	220	69	10	3,500
VTH0500	5	180	11	120	8.4	220	70	10	3,650
VTH0600	6	210	16	140	10.4	245	135	5	3,990
VTH0800	8	250	19	175	11.6	280	200	5	4,590

• Nickel Chrome Plating

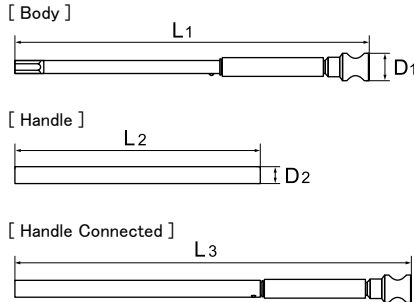

The handle can be stored in the body, so it takes up less storage space than existing T-shaped hexagon key wrenches, making it convenient to carry around.  
The quick-turn collar enables speedy work.  
The handle slides for use in either T or L configuration, depending on work requirements.

## Plastic Handle type / Metric

Code	○ mm	L mm	ℓ mm	W mm	Weight g		Price ¥
ATL0250	2.5	152	127	75	20	10	730
ATL0300	3	170	145	75	22	10	800
ATL0400	4	182	152	90	40	10	890
ATL0500	5	206	176	90	60	10	1,020
ATL0600	6	228	198	90	75	10	1,160

• Nickel Chrome Plating  
• Plastic Handle

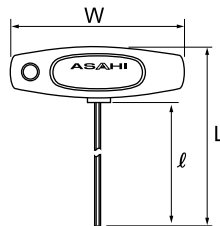

# Hexlobe

## Short type

Code		L mm	ℓ mm	Weight g		Price ¥
ATX010	T10H	56	18	4	10	890
ATX015	T15H	63	20	8	10	960
ATX020	T20H	72	23	10	10	1,030
ATX025	T25H	80	28	16	10	1,150
ATX027	T27H	90	32	26	10	1,150
ATX030	T30H	100	36	29	10	1,210
ATX040	T40H	112	40	44	10	1,280

- Tamperproof Screw
- Electroless Nickel Plating
- Blister pack

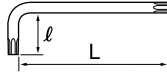

**7Pcs.** T10 T15 T20 T25 T27 T30 T40

Code		Weight g		Price ¥
ATXS710	ATX- T10H, T15H, T20H, T25H, T27H, T30H, T40H	150	10	7,500

- Plastic Holder
- Blister pack 190 × 90 × 25mm



# Holder

## Connect holer

Code	Hex Key Adjustables mm	H <sub>1</sub> mm	H <sub>2</sub> mm	D mm	L mm	Weight g		Price ¥
AI0152	1.5, 2	16	15	15	38	6.8	5	340
AI0253	2.5, 3	16	15	15	38	6.5	5	340
AI0400	4	16	15	15	38	6.5	5	340
AI0500	5	16	15	15	38	6.2	5	340
AI0600	6	16	15	15	38	5.8	5	340
AI0800	8	16	15	15	38	5	5	340
AI1000	10	16	15	15	38	3.6	5	340

- Vinyl Pack
- Polypropylene

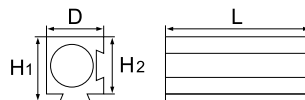

**7Pcs.** Code **AIS0710** Price **¥ 2,330**

Set Contains	
Connect Holder	AI- 1.5/2, 2.5/3, 4, 5, 6, 8, 10

- Weight 150g
- Vinyl Pack



# with the magnet

Code	Hex Key Adjustables mm	Weight g	Price ¥
AH1200	1.5 ~ 12mm	160	4,830

- Plastic
- Storage Box 140 × 75 × 50mm





# Torque Wrenches

## Open End Head



	LCS02	LCS04	LCS09	LCS18
Torque wrench insertion diameter	Φ10 mm	Φ12 mm	Φ15 mm	Φ18 mm
mm Width across flat				
7	●			
8	●	●		
9	●	●		
10	●	●		
11	●	●		
12	●	●	●	
13	●	●	●	
14	●	●	●	
17	●	●	●	●
19	●	●	●	●
21	●	●	●	●
22	●	●	●	●
24	●	●	●	●
27	●	●	●	●
30			●	●
32				●
36				●
41				●

## Ring Head



	LCR04	LCR09	LCR18
Torque wrench insertion diameter	Φ12 mm	Φ15 mm	Φ18 mm
mm Width across flat			
8	●		
10	●		
11	●		
12	●	●	
13	●	●	
14	●	●	
17	●	●	●
19	●	●	●
21		●	
22	●	●	●
24		●	●
27		●	●
30		●	●
32			●
36			●
41			●

## Hexagon Head



	LCX02	LCX04	LCX09	LCX18
Torque wrench insertion diameter	Φ10 mm	Φ12 mm	Φ15 mm	Φ18 mm
mm Width across flat				
2.5	●			
3	●			
4	●	●		
5		●	●	
6	●	●	●	●
8	●	●	●	●
10		●	●	●
12			●	●
14				●

## Hook Spanner Head



	LCK09	LCK18
Torque wrench insertion diameter	Φ15 mm	Φ18 mm
mm Bearing nut diameter		
30~32	●	
34~38	●	
40~42	●	
45~48	●	
50~55	●	
58~65		●
65~70		●
70~75		●
80~85		●
92~100		●

## Ratchet Head



	LQ3045	LQ3055	LQ4065	LQ4080
Torque wrench insertion diameter	Φ10 mm	Φ12 mm	Φ15 mm	Φ18 mm
Insertion angle mm	9.5		12.7	
	●	●	●	●



## Torque Wrench



	Φ10 mm	Φ12 mm	Φ15 mm	Φ18 mm
Replacement head insertion diameter				
Torque range N·m				
5~25	●			
10~50		●		
20~100			●	
40~200				●



## LCS Open End Head, Metric

### Torque wrench with 10 mm insertion diameter



Code			effective length ℓ mm	B mm	h mm	H mm	L mm	Weight g		Price ¥
LCS0207	7	10	45	29	7	16	55	57	1	2,800
LCS0208	8	10	45	29	7	16	55	56	1	2,800
LCS0209	9	10	45	29	7	16	55	56	1	2,800
LCS0210	10	10	45	29	7	16	55	56	1	2,800
LCS0211	11	10	45	29	7	16	55	53	1	2,800
LCS0212	12	10	45	32	7	16	55.5	57	1	3,000
LCS0213	13	10	45	32	7	16	55.5	57	1	3,000
LCS0214	14	10	45	32	7	16	55.5	56	1	3,000
LCS0217	17	10	45	39	8	16	57.5	72	1	3,200
LCS0219	19	10	45	39	8	16	57.5	69	1	3,200
LCS0221	21	10	45	39	8	16	57.5	65	1	3,200
LCS0222	22	10	45	39	8	16	57.5	63	1	3,200
LCS0224	24	10	45	45	8	16	60	78	1	7,400
LCS0227	27	10	45	45	8	16	60	72	1	7,400





### Torque wrench with 12 mm insertion diameter

Code			effective length ℓ mm	B mm	h mm	H mm	L mm	Weight g		Price ¥
LCS0408	8	12	55	32	8	20	64	110	1	3,500
LCS0409	9	12	55	32	8	20	64	110	1	3,500
LCS0410	10	12	55	32	8	20	64	120	1	3,500
LCS0411	11	12	55	32	8	20	64	120	1	3,500
LCS0412	12	12	55	36	10	20	64	120	1	3,600
LCS0413	13	12	55	36	10	20	64	120	1	3,600
LCS0414	14	12	55	36	10	20	64	120	1	3,600
LCS0417	17	12	55	44	10	20	67	140	1	3,800
LCS0419	19	12	55	44	10	20	67	140	1	3,800
LCS0421	21	12	55	44	10	20	67	138	1	3,800
LCS0422	22	12	55	44	10	20	67	130	1	3,800
LCS0424	24	12	55	50	10	20	73	140	1	7,800
LCS0427	27	12	55	50	10	20	73	133	1	7,800

### Torque wrench with 15 mm insertion diameter

Code			effective length ℓ mm	B mm	h mm	H mm	L mm	Weight g		Price ¥
LCS0912	12	15	65	40	10	24	75	200	1	3,900
LCS0913	13	15	65	40	10	24	75	200	1	3,900
LCS0914	14	15	65	40	10	24	75	200	1	3,900
LCS0917	17	15	65	48	12	24	79	240	1	4,100
LCS0919	19	15	65	48	12	24	79	240	1	4,100
LCS0921	21	15	65	48	12	24	79	230	1	4,100
LCS0922	22	15	65	48	12	24	79	220	1	4,100
LCS0924	24	15	65	57	12	24	81	270	1	4,200
LCS0927	27	15	65	57	12	24	81	250	1	4,200
LCS0930	30	15	65	57	12	24	81	230	1	4,200

### Torque wrench with 18 mm insertion diameter

Code			effective length ℓ mm	B mm	h mm	H mm	L mm	Weight g		Price ¥
LCS1817	17	18	80	56	14	28	94	390	1	4,700
LCS1819	19	18	80	56	14	28	94	380	1	4,700
LCS1821	21	18	80	56	14	28	94	360	1	4,700
LCS1822	22	18	80	56	14	28	94	350	1	4,700
LCS1824	24	18	80	64	14	28	97	430	1	5,400
LCS1827	27	18	80	64	14	28	97	400	1	5,400
LCS1830	30	18	80	64	14	28	97	400	1	5,400
LCS1832	32	18	80	75	14	28	102	480	1	6,600
LCS1836	36	18	80	75	14	28	102	470	1	6,600
LCS1841	41	18	80	75	14	28	102	440	1	6,600

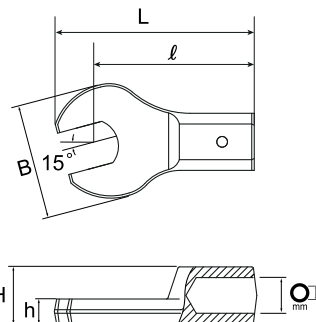

• Nickel Chrome Plating

TOOL SETS

SPANNERS

STRIKING FACE WRENCHES

HOOK SPANNERS

DX2000 TOOLS  
HEXAGON KEY WRENCHES

HEXAGON KEY WRENCHES

TORQUE WRENCHES

CROWFOOT WRENCHES

SOCKETS

OTHER TOOLS

## LCS Open End Head, Metric

25N·m

**9Pcs.**

Code **LCS1000** Price **¥45,100**

Set Contains	
Torque Wrench	LC023N (Torque Range 5 ~ 25N·m)
Open End Head	LCS02- 7, 8, 9, 10, 12, 13, 14, 17

- Weight 1.7kg
- Tool Box 135 × 335 × 42mm



LCS1000

50N·m

**9Pcs.**

Code **LCS2000** Price **¥51,700**

Set Contains	
Torque Wrench	LC045N (Torque Range 10 ~ 50N·m)
Open End Head	LCS04- 8, 10, 11, 12, 13, 14, 17, 19

- Weight 2.35kg
- Tool Box 135 × 335 × 42mm



LCS2000

100N·m

**9Pcs.**

Code **LCS3000** Price **¥57,200**

Set Contains	
Torque Wrench	LC090N (Torque Range 20 ~ 100N·m)
Open End Head	LCS09- 12, 13, 14, 17, 19, 22, 24, 27

- Weight 3.8kg
- Tool Box 160 × 450 × 42mm



LCS3000

200N·m

**9Pcs.**

Code **LCS4000** Price **¥71,900**

Set Contains	
Torque Wrench	LC180N (Torque Range 40 ~ 200N·m)
Open End Head	LCS18- 17, 19, 22, 24, 27, 30, 32, 36

- Weight 6.5kg
- Tool Box 180 × 520 × 63mm



LCS4000

TOOL SETS

SPANNERS

STRIKING FACE WRENCHES

HOOK SPANNERS

DX2000 TOOLS  
HEXAGON KEY WRENCHES

HEXAGON KEY WRENCHES

TORQUE WRENCHES



CROWFOOT WRENCHES

SOCKETS

OTHER TOOLS



## LCR Ring Head, Metric

### Torque wrench with 12 mm insertion diameter



Code	 mm	 mm	$l$ effective length mm	D mm	h mm	H mm	L mm	Weight g		Price ¥
LCR0408	8	12	55	19	10	20	64.5	105	1	3,300
LCR0410	10	12	55	19	10	20	64.5	105	1	3,300
LCR0411	11	12	55	22	10	20	66	110	1	3,300
LCR0412	12	12	55	22	10	20	66	110	1	3,400
LCR0413	13	12	55	22	10	20	66	110	1	3,400
LCR0414	14	12	55	22	10	20	66	105	1	3,400
LCR0417	17	12	55	32	10	20	71	120	1	3,600
LCR0419	19	12	55	32	10	20	71	120	1	3,600
LCR0422	22	12	55	32	10	20	71	110	1	3,600



### Torque wrench with 15 mm insertion diameter

Code	 mm	 mm	$l$ effective length mm	D mm	h mm	H mm	L mm	Weight g		Price ¥
LCR0912	12	15	65	25	13	24	77.5	200	1	3,700
LCR0913	13	15	65	25	13	24	77.5	200	1	3,700
LCR0914	14	15	65	25	13	24	77.5	190	1	3,700
LCR0917	17	15	65	34	13	24	82	210	1	3,900
LCR0919	19	15	65	34	13	24	82	210	1	3,900
LCR0921	21	15	65	34	13	24	82	210	1	3,900
LCR0922	22	15	65	34	13	24	82	200	1	3,900
LCR0924	24	15	65	42	13	24	86	220	1	4,000
LCR0927	27	15	65	42	13	24	86	210	1	4,000
LCR0930	30	15	65	42	13	24	86	200	1	4,000

### Torque wrench with 18 mm insertion diameter

Code	 mm	 mm	$l$ effective length mm	D mm	h mm	H mm	L mm	Weight g		Price ¥
LCR1817	17	18	80	35	15	28	97.5	340	1	4,100
LCR1819	19	18	80	35	15	28	97.5	340	1	4,100
LCR1822	22	18	80	35	15	28	97.5	340	1	4,100
LCR1824	24	18	80	45	15	28	102.5	360	1	5,200
LCR1827	27	18	80	45	15	28	102.5	350	1	5,200
LCR1830	30	18	80	45	15	28	102.5	320	1	5,200
LCR1832	32	18	80	58	15	28	109	400	1	6,200
LCR1836	36	18	80	58	15	28	109	380	1	6,200
LCR1841	41	18	80	58	15	28	109	340	1	6,200

• Nickel Chrome Plating

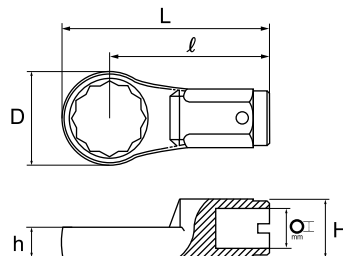

TOOL SETS

SPANNERS

STRIKING FACE WRENCHES

HOOK SPANNERS

DX2000 TOOLS  
HEXAGON KEY WRENCHES

HEXAGON KEY WRENCHES

TORQUE WRENCHES

CROWFOOT WRENCHES

SOCKETS

OTHER TOOLS

## LCR Ring Head, Metric

50N·m

**9Pcs.**

Code	<b>LCR2000</b>	Price	<b>¥49,600</b>
------	----------------	-------	----------------

Set Contains

Torque Wrench	LC045N (Torque Range 10 ~ 50N·m)
Ring Head	LCR04- 8, 10, 11, 12, 13, 14, 17, 19

- Weight 2.3kg
- Tool Box 135 × 335 × 42mm



LCR2000

100N·m

**9Pcs.**

Code	<b>LCR3000</b>	Price	<b>¥55,500</b>
------	----------------	-------	----------------

Set Contains

Torque Wrench	LC090N (Torque Range 20 ~ 100N·m)
Ring Head	LCR09- 12, 13, 14, 17, 19, 22, 24, 27

- Weight 3.55kg
- Tool Box 160 × 450 × 42mm



LCR3000

200N·m

**9Pcs.**

Code	<b>LCR4000</b>	Price	<b>¥70,100</b>
------	----------------	-------	----------------

Set Contains

Torque Wrench	LC180N (Torque Range 40 ~ 200N·m)
Ring Head	LCR18- 17, 19, 22, 24, 27, 30, 32, 36

- Weight 6.2kg
- Tool Box 180 × 520 × 63mm



LCR4000

TOOL SETS

SPANNERS

STRIKING FACE WRENCHES

HOOK SPANNERS

DX2000 TOOLS  
HEXAGON KEY WRENCHES

HEXAGON KEY WRENCHES

TORQUE WRENCHES

CROWFOOT WRENCHES

SOCKETS

OTHER TOOLS

## LCX Hexagon Head, Metric

### Torque wrench with 10 mm insertion diameter

Code	$\varnothing$ mm	$\varnothing$ mm	$l$ effective length mm	$h$ mm	$H$ mm	$L$ mm	Weight g		Price ¥
LCX0225	2.5	10	45	27	16	46.3	56	1	4,100
LCX0203	3	10	45	29	16	46.5	55	1	4,100
LCX0204	4	10	45	35	16	47	55	1	4,200
LCX0205	5	10	45	38	16	47.5	55	1	4,400
LCX0206	6	10	45	43	16	48	56	1	4,400
LCX0208	8	10	45	48	16	49	60	1	4,500

### Torque wrench with 12 mm insertion diameter

Code	$\varnothing$ mm	$\varnothing$ mm	$l$ effective length mm	$h$ mm	$H$ mm	$L$ mm	Weight g		Price ¥
LCX0404	4	12	55	38	18	57	90	1	3,500
LCX0405	5	12	55	41.5	18	57.5	100	1	4,200
LCX0406	6	12	55	46	18	58	100	1	5,000
LCX0408	8	12	55	51	18	59	110	1	5,700
LCX0410	10	12	55	56	18	60	130	1	6,500

### Torque wrench with 15 mm insertion diameter

Code	$\varnothing$ mm	$\varnothing$ mm	$l$ effective length mm	$h$ mm	$H$ mm	$L$ mm	Weight g		Price ¥
LCX0905	5	15	65	44.5	23	67.5	170	1	4,400
LCX0906	6	15	65	49	23	68	170	1	5,200
LCX0908	8	15	65	54	23	69	180	1	6,000
LCX0910	10	15	65	59	23	70	200	1	6,800
LCX0912	12	15	65	65	23	71	225	1	7,500

### Torque wrench with 18 mm insertion diameter

Code	$\varnothing$ mm	$\varnothing$ mm	$l$ effective length mm	$h$ mm	$H$ mm	$L$ mm	Weight g		Price ¥
LCX1806	6	18	80	50.5	26	83	270	1	4,800
LCX1808	8	18	80	55.5	26	84	280	1	5,600
LCX1810	10	18	80	60.5	26	85	290	1	7,400
LCX1812	12	18	80	66.5	26	86	300	1	8,200
LCX1814	14	18	80	78.5	26	87	350	1	8,800

- Body : Nickel Chrome Plating
- Hex : Black Finishing

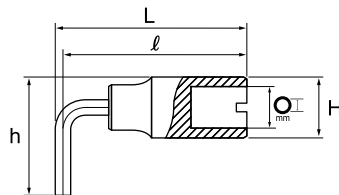



## LCX Hexagon Head, Metric

25N·m

**7Pcs.**

Code **LCX1000** Price **¥44,600**

Set Contains	
Torque Wrench	LC023N (Torque Range 5 ~ 25N·m)
Hexagon Head	LCX02- 2.5, 3, 4, 5, 6, 8

- Weight 1.57kg
- Tool Box 135 × 335 × 42mm



LCX1000

50N·m

**6Pcs.**

Code **LCX2000** Price **¥44,900**

Set Contains	
Torque Wrench	LC045N (Torque Range 10 ~ 50N·m)
Hexagon Head	LCX04- 4, 5, 6, 8, 10

- Weight 1.9kg
- Tool Box 135 × 335 × 42mm



LCX2000

100N·m

**6Pcs.**

Code **LCX3000** Price **¥51,300**

Set Contains	
Torque Wrench	LC090N (Torque Range 20 ~ 100N·m)
Ring Head	LCX09- 5, 6, 8, 10, 12

- Weight 3.0kg
- Tool Box 160 × 450 × 42mm



LCX3000

200N·m

**6Pcs.**

Code **LCX4000** Price **¥60,800**

Set Contains	
Torque Wrench	LC180N (Torque Range 40 ~ 200N·m)
Ring Head	LCX18- 6, 8, 10, 12, 14

- Weight 4.7kg
- Tool Box 180 × 520 × 63mm



LCX4000

TOOL SETS

SPANNERS

STRIKING FACE WRENCHES

HOOK SPANNERS

DX2000 TOOLS  
HEXAGON KEY WRENCHES

HEXAGON KEY WRENCHES

TORQUE WRENCHES



CROWFOOT WRENCHES

SOCKETS

OTHER TOOLS



# LCK Hook Spanner Head

## Torque wrench with 15 mm insertion diameter

Code	 mm	 mm	$\ell$ effective length mm	C mm	h mm	H mm	L mm	Weight g		Price ¥
LCK0930	30~32	15	65	2.3	5	28	81	83	1	7,700
LCK0934	34~38	15	65	2.5	6	29	85	101	1	8,000
LCK0940	40~42	15	65	2.5	6	29	88	103	1	8,200
LCK0945	45~48	15	65	2.5	6.5	29.5	91	123	1	8,800
LCK0950	50~55	15	65	2.5	6.5	29.5	94	127	1	9,000



## Torque wrench with 18 mm insertion diameter

Code	 mm	 mm	$\ell$ effective length mm	C mm	h mm	H mm	L mm	Weight g		Price ¥
LCK1858	58~65	18	80	3	7.5	33.5	112	193	1	9,800
LCK1865	65~70	18	80	3	7.5	33.5	112	195	1	10,100
LCK1870	70~75	18	80	3.5	8	34	117	220	1	10,400
LCK1880	80~85	18	80	3.5	8.5	34.5	121	280	1	11,800
LCK1892	92~100	18	80	4	8.5	34.5	126	283	1	12,300

• Nickel Chrome Plating

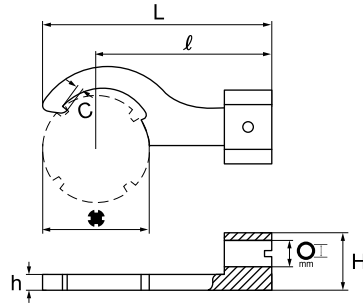

## 100N·m

**6Pcs.**

Code **LCK3000** Price **¥66,000**

Set Contains

Torque Wrench	LC090N (Torque Range 20 ~ 100N·m)
Hook Spanner Head	LCK09- 30, 34, 40, 45, 50

- Weight 2.7kg
- Tool Box 160 × 450 × 42mm



LCK3000

## 200N·m

**6Pcs.**

Code **LCK4000** Price **¥84,000**

Set Contains

Torque Wrench	LC180N (Torque Range 40 ~ 200N·m)
Hook Spanner Head	LCK18- 58, 65, 70, 80, 92

- Weight 4.3kg
- Tool Box 180 × 520 × 63mm



LCK4000

TOOL SETS

SPANNERS

STRIKING FACE WRENCHES

HOOK SPANNERS

DX2000 TOOLS  
HEXAGON KEY WRENCHES

HEXAGON KEY WRENCHES

TORQUE WRENCHES

CROWFOOT WRENCHES

SOCKETS

OTHER TOOLS

## LQ Ratchet Head

Code	$\phi$ mm	$\phi$ mm	$l$ effective length mm	b mm	h mm	H mm	L mm	Weight g		Price ¥
LQ3045	9.5	10	45	31	14	16	60	116	1	8,800
LQ3055	9.5	12	55	32	14	18	71	140	1	8,800
LQ4065	12.7	15	65	39	17	23	84.5	245	1	9,300
LQ4080	12.7	18	80	46	19	26	103	390	1	13,800

• Nickel Chrome Plating

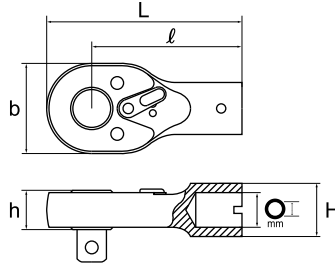

### 25N·m

**11Pcs.**

Code	<b>LCV1000</b>	Price	<b>¥40,700</b>
------	----------------	-------	----------------

Set Contains

Torque Wrench	LC023N (Torque Range 5 ~ 25N·m)
Ratchet Head	LQ3045
Socket (12pt.)	VS3- 7, 8, 9, 10, 12, 13, 14, 17
Extension Bar	VE0375 (75mm)

- Weight 1.65kg
- Tool Box 135 × 335 × 42mm



LCV1000

### 50N·m

**11Pcs.**

Code	<b>LCV2000</b>	Price	<b>¥42,100</b>
------	----------------	-------	----------------

Set Contains

Torque Wrench	LC045N (Torque Range 10 ~ 50N·m)
Ratchet Head	LQ3055
Socket (12pt.)	VS3- 8, 10, 11, 12, 13, 14, 17, 19
Extension Bar	VE0375 (75mm)

- Weight 2.1kg
- Tool Box 135 × 335 × 42mm



LCV2000

### 100N·m

**11Pcs.**

Code	<b>LCV3000</b>	Price	<b>¥46,100</b>
------	----------------	-------	----------------

Set Contains

Torque Wrench	LC090N (Torque Range 20 ~ 100N·m)
Ratchet Head	LQ4065
Socket (12pt.)	VS4- 12, 13, 14, 17, 19, 22, 24, 27
Extension Bar	VE0415 (150mm)

- Weight 3.2kg
- Tool Box 160 × 450 × 42mm



LCV3000

### 200N·m

**11Pcs.**

Code	<b>LCV4000</b>	Price	<b>¥57,200</b>
------	----------------	-------	----------------

Set Contains

Torque Wrench	LC180N (Torque Range 40 ~ 200N·m)
Ratchet Head	LQ4080
Socket (12pt.)	VS4- 14, 17, 19, 22, 24, 27, 30, 32
Extension Bar	VE0425 (250mm)

- Weight 5.2kg
- Tool Box 180 × 520 × 63mm



LCV4000

TOOL SETS

SPANNERS

STRIKING FACE WRENCHES

HOOK SPANNERS

DX2000 TOOLS

HEXAGON KEY WRENCHES

TORQUE WRENCHES

GROUND WRENCHES

SOCKETS

OTHER TOOLS

## LC Torque Wrench, Pre-set Type, with Tool Carrier for Insert Tool

Code	Torque Range N·m	mm	effective length mm	L mm	Weight g	Price ¥
LC023N	5~25	10	190	208	200	18,600
LC045N	10~50	12	215	238	380	19,700
LC090N	20~100	15	320	331	600	21,400
LC180N	40~200	18	445	455	1,350	25,800

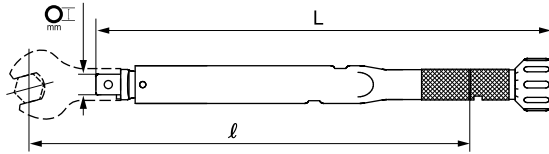

### Features of th Product

- When the pre-set torque is reached, a click can be felt and heard.
- Accuracy  $\pm 3\%$
- Interchangeable heads are available with various adjustables.

## LCQ Torque Wrench with Ratchet Head, with Tool Carrier for Insert Tool

Code	Torque Range N·m	mm	mm	effective length mm	b mm	h mm	L mm	Weight g	Price ¥
LCQ023N	5~25	10	9.5	190	31	14	255	315	27,900
LCQ045N	10~50	12	9.5	215	32	14	293	520	29,000
LCQ090N	20~100	15	12.7	320	39	17	398	845	31,500
LCQ180N	40~200	18	12.7	445	46	19	536	1,740	39,000

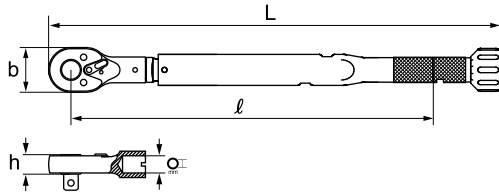

### Features of th Product

- When the pre-set torque is reached, a click can be felt and heard.
- Accuracy  $\pm 3\%$
- Interchangeable heads are available with various adjustables.

# Crowfoot Wrench, Spanner Type

## Crowfoot Wrench, Spanner Type



	VC2	VC3	VC4
Insertion angle mm	6.3	9.5	12.7
mm Width across flat			
5.5	●		
6	●		
7	●		
8	●	●	
9		●	
10	●	●	
12	●	●	
13	●	●	
14		●	
15		●	
16		●	
17		●	●
19		●	●
21		●	
22		●	●
24		●	●
26		●	
27		●	●
29		●	
30		●	●
32		●	●
36			●
41			●
46			●
50			●
55			●
60			●

## Long Crowfoot Wrench, Spanner Type



	VCL3	VCL4
Insertion angle mm	9.5	12.7
mm Width across flat		
10	●	
12	●	
13	●	
14	●	
17	●	
19	●	●
22		●
24		●
27		●
30		●
32		●
36		●

## Crowfoot Wrench, Flare Nut Type



	VCF3
Insertion angle mm	9.5
mm Width across flat	
8	●
10	●
12	●
14	●
17	●
19	●
22	●

## Crowfoot Wrench, Hook Spanner Type



	VCK3
Insertion angle mm	9.5
mm Width across flat	
25~28	●
30~32	●
34~38	●
40~42	●
44~52	●
50~55	●
58~65	●

# 1/4" (6.3mm) - Drive

## VC2 Crowfoot Wrench, Spanner Type

Code	mm	B mm	b mm	H mm	L mm	effective length ℓ mm	Weight g		Price ¥
VC2005	5.5	16	12.7	6	22	12	10	-	2,160
VC2006	6	16	12.7	6	22	12	10	-	2,160
VC2007	7	17	12.7	6	24	13	11	-	2,190
VC2008	8	17	12.7	6	25	14	11	-	2,300
VC2010	10	19	12.7	6	27	15	12	-	2,500
VC2012	12	22.5	12.7	6	29	16	14.5	-	2,620
VC2013	13	24	12.7	6	30	16	15.5	-	2,790



Hand Tool



• Nickel Chrome Plating

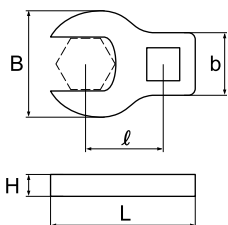

### 【For use with torque wrench】

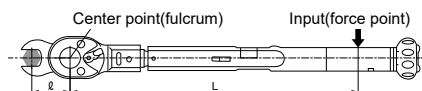

Torque conversion formula :

$$\frac{L}{(L + \ell)} \times \text{required torque value} = \text{input torque value}$$

EX)When using a torque wrench with an effective length of 190 mm and VC2012 to tighten an object at 9 N·m.

L (Effective length of torque wrench) : 190mm  
 ℓ (Effective length of crowfoot wrench) : 16mm  
 Required torque value : 9N·m

$$\text{Torque conversion formula : } \frac{190}{(190+16)} \times 9 \approx 8.3$$

→When the torque wrench is set to 8.3N·m, the torque can be tightened with 9N·m

**9Pcs.**

Code **VCS2090**

Price **¥25,900**

#### Set Contains

Crowfoot Wrench	VC2- 5, 6, 7, 8, 10, 12, 13
Extension Bar	VE0215
Ratchet Handle	VR0215

• Weight 580g

• Tool Box 110 × 200 × 35mm



Please do not use the product of this mark with the power tool including the impact wrench.

**ASAHI**  
TOOLS

TOOL SETS

SPANNERS

STRIKING FACE WRENCHES

HOOK SPANNERS

HEXAGON KEY WRENCHES

HEXAGON KEY WRENCHES

TORQUE WRENCHES

CROWFOOT WRENCHES

SOCKETS

OTHER TOOLS



# 3/8" (9.5mm) - Drive

## VC3 Crowfoot Wrench, Spanner Type

Code	mm	B mm	b mm	H mm	h mm	L mm	effective length ℓ mm	Weight g	Price ¥
VC3008	8	21	17	10	6.3	31.6	15.6	21	- 2,090
VC3009	9	21	17	10	6.3	31.4	16.2	20	- 2,090
VC3010	10	21	17	10	6.3	31.2	16.8	20	- 2,090
VC3012	12	24	17	10	6.3	33.7	17.9	25	- 2,090
VC3013	13	24	17	10	6.3	32.7	18.5	25	- 2,090
VC3014	14	24	17	10	6.3	32.6	19.1	25	- 2,090
VC3015	15	28.8	17	10	6.3	37.5	20.2	30	- 2,230
VC3016	16	28.8	17	10	6.3	37.4	20.7	29	- 2,230
VC3017	17	28.8	17	10	6.3	37.4	21.3	27	- 2,230
VC3019	19	38	19	10	6.3	42.6	24	42	- 2,380
VC3021	21	38	19	10	6.3	41.6	25.1	40	- 2,380
VC3022	22	41	19	10	6.3	46	25.7	48	- 3,280
VC3024	24	41	19	10	6.3	44	26.8	45	- 3,280
VC3026	26	46	19	11.5	9.5	50	28	80	- 5,100
VC3027	27	46	19	11.5	9.5	50	28.6	70	- 5,100
VC3029	29	50	19	11.5	9.5	51	29.7	75	- 6,100
VC3030	30	50	19	11.5	9.5	51	30.3	75	- 6,100
VC3032	32	50	19	11.5	9.5	50	31.5	72	- 6,100

• Nickel Chrome Plating

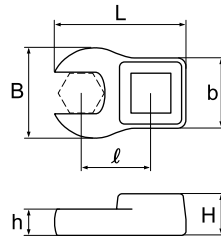

TOOL SETS  
SPANNERS  
STRIKING FACE WRENCHES  
HOOK SPANNERS  
DX2000 TOOLS  
HEXAGON KEY WRENCHES  
HEXAGON KEY WRENCHES  
TORQUE WRENCHES  
CROWFOOT WRENCHES  
SOCKETS  
OTHER TOOLS

**11Pcs.**

Code **VCS3110** Price **¥24,500**

Set Contains

Crowfoot Wrench	VC3- 8, 10, 12, 13, 14, 16, 17, 19, 21, 22, 24
Holder	275mm

- Weight 380g
- Storage Box 130 × 350 × 55mm

**NEW**



VCS3110

**13Pcs.**

Code **VCS3131** Price **¥34,500**

Set Contains

Crowfoot Wrench	VC3- 8, 10, 12, 13, 14, 16, 17, 19, 21, 22, 24
Extension Bar	VEB330 Flexible Type
Ratchet Handle	VRL3180 <b>Revowave</b>

- Weight 1.8kg
- Tool Box 130 × 350 × 55mm



VCS3131

**18Pcs.**

Code **VCS3180** Price **¥56,300**

Set Contains

Crowfoot Wrench	VC3- 8, 9, 10, 12, 13, 14, 15, 16, 17, 19, 21, 22, 24, 26, 27, 29, 30, 32
Holder	420mm

- Weight 970g
- Storage Box 115 × 440 × 30mm





VCS3180



Please do not use the product of this mark with the power tool including the impact wrench.

# 3/8" (9.5mm) - Drive

## VCL3 Long Crowfoot Wrench, Spanner Type

Code	 mm	B mm	b mm	H mm	L mm	effective length ℓ mm	Weight g		Price ¥
VCL3010	10	22	17	8	50	64.5	55	-	2,640
VCL3012	12	25	17	8	50	66	56.5	-	2,810
VCL3013	13	26	17	8	50	65.5	57.5	-	2,810
VCL3014	14	28	17	8	50	66	58.5	-	2,900
VCL3017	17	32	19	8	50	67.5	67.5	-	2,930
VCL3019	19	38	21	8	50	68.5	81.5	-	3,020

• Nickel Chrome Plating

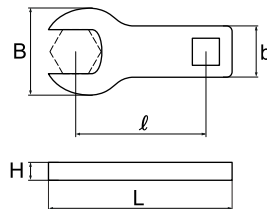

<b>6Pcs.</b>	Code	<b>VCLS360</b>	Price	<b>¥18,400</b>
Set Contains				
Crowfoot Wrench	VCL3- 10, 12, 13, 14, 17, 19			

- Weight 424g
- Storage Box 85 × 235 × 25mm



TOOL SETS

SPANNERS

STRIKING FACE WRENCHES

HOOK SPANNERS

DX2000 TOOLS  
HEXAGON KEY WRENCHES

HEXAGON KEY WRENCHES

TORQUE WRENCHES

CROWFOOT WRENCHES

SOCKETS

OTHER TOOLS



Please do not use the product of this mark with the power tool including the impact wrench.

# 3/8" (9.5mm) - Drive

## VCK3 Crowfoot Wrench, Hook Spanner Type

Code	 mm	C mm	T mm	H mm	L mm	effective length ℓ mm	Weight g	Price ¥
VCK3025	25~28	3	6	34	74	45	50	2,200
VCK3030	30~32	3	6	37	76	45	53	2,200
VCK3034	34~38	3.5	6	40	79	45	59	2,300
VCK3040	40~42	3.5	6	44	82	45	63	2,300
VCK3044	44~52	4	6	47	84	45	67	2,300
VCK3050	50~55	4.5	6	54	87	45	75	2,400
VCK3058	58~65	5	6	58	90	45	81	2,500

• Nickel Chrome Plating



NEW

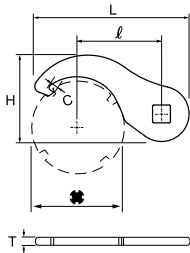

### 【For use with torque wrench】

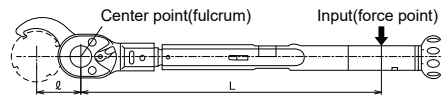

Torque conversion formula :

$$\frac{L}{(L + \ell)} \times \text{required torque value} = \text{input torque value}$$

EX)When using a torque wrench with an effective length of 190 mm and VCK3058 to tighten an object at 8 N·m.

L (Effective length of torque wrench) : 190mm  
 ℓ (Effective length of hook crowfoot wrench) : 45mm  
 Required torque value : 8N·m

$$\text{Torque conversion formula : } \frac{190}{(190+45)} \times 8 \approx 6.5$$

→When the torque wrench is set to 6.5N·m, the torque can be tightened with 8N·m

## VCF3 Crowfoot Wrench, Flare Nut Type

Code	 mm	D mm	T mm	L mm	effective length ℓ mm	Weight g	Price ¥
VCF3008	8	18.3	8	46	30	36	2,300
VCF3010	10	22.0	8	48	30	41	2,400
VCF3012	12	25.5	8	48	30	45	2,400
VCF3014	14	30.0	8	50	30	52	2,550
VCF3017	17	35.5	8	54	30	65	2,640
VCF3019	19	40.0	8	56	30	76	2,730
VCF3022	22	43.5	8	58	30	83	2,790

• Nickel Chrome Plating



NEW

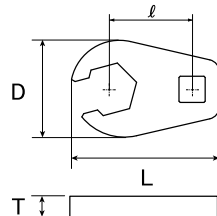

Please do not use the product of this mark with the power tool including the impact wrench.

# 1/2" (12.7mm) - Drive

## VC4 Crowfoot Wrench, Spanner Type

Code	mm	B mm	b mm	H mm	L mm	effective length ℓ mm	Weight g		Price ¥
VC4017	17	32	22	12	55	33	80	-	5,200
VC4019	19	36	22	12	57	35	90	-	5,200
VC4022	22	42	24	12	61	38	113	-	5,200
VC4024	24	46	26	12	64	38	128	-	5,400
VC4027	27	50	27	12	67.5	40	145	-	5,700
VC4030	30	54	28	12	73	43	164	-	6,100
VC4032	32	56	28	12	73	43	165	-	6,300
VC4036	36	62	30	12	77	45.5	191	-	6,400
VC4041	41	68	32	12	86	50	224	-	7,000
VC4046	46	74	32	12	91	52	254	-	11,300
VC4050	50	79	34	12	94	54	274	-	11,600
VC4055	55	84	34	12	101.5	57	314	-	12,600
VC4060	60	89	34	12	103.5	59	320	-	13,000



• Nickel Chrome Plating

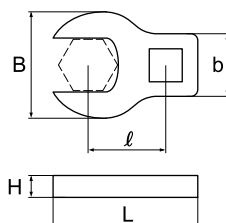

<b>8Pcs.</b>	Code	<b>VCS4080</b>	Price	<b>¥43,100</b>
Set Contains				
Crowfoot Wrench	VC4- 17, 19, 22, 24, 27, 30, 32, 36			
Holder	275mm			

- Weight 1.2kg
- Storage Box 290 × 130 × 30mm

NEW



VCS4080

<b>10Pcs.</b>	Code	<b>VCS4100</b>	Price	<b>¥55,400</b>
Set Contains				
Crowfoot Wrench	VC4- 17, 19, 22, 24, 27, 30, 32, 36			
Extension Bar	VEB438 Flexible Type			
Ratchet Handle	VRL4250 <b>Revo wave</b>			

- Weight 3.4kg
- Tool Box 150 × 450 × 55mm



VCS4100

<b>13Pcs.</b>	Code	<b>VCS4130</b>	Price	<b>¥96,800</b>
Set Contains				
Crowfoot Wrench	VC4- 17, 19, 22, 24, 27, 30, 32, 36, 41, 46, 50, 55, 60			
Holder	220mm / 275mm			

- Weight 2.7kg
- Storage Box 200 × 510 × 50mm



VCS4130

TOOL SETS

SPANNERS

STRIKING FACE WRENCHES

HOOK SPANNERS

DX2000 TOOLS  
HEXAGON KEY WRENCHES

HEXAGON KEY WRENCHES

TORQUE WRENCHES

CROWFOOT WRENCHES

SOCKETS

OTHER TOOLS



Please do not use the product of this mark with the power tool including the impact wrench.

# 1/2" (12.7mm) - Drive

## VCL4 Long Crowfoot Wrench, Spanner Type

Code	mm	B mm	b mm	H mm	L mm	effective length ℓ mm	Weight g		Price ¥
VCL4019	19	36	22	12	86	65	147	-	5,400
VCL4022	22	42	24	12	87	65	169	-	5,400
VCL4024	24	46	26	12	89.5	65	190	-	5,700
VCL4027	27	50	28	12	91.5	65	207	-	6,000
VCL4030	30	54	28	12	93.5	65	218	-	6,400
VCL4032	32	56	28	12	93	65	218	-	6,700
VCL4036	36	62	30	12	95	65	243	-	6,800

• Nickel Chrome Plating

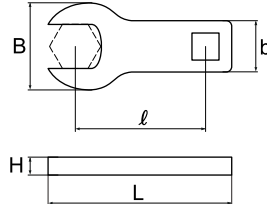

NEW



<b>7Pcs.</b>	Code	<b>VCLS470</b>	Price	<b>¥43,400</b>
Set Contains				
Crowfoot Wrench	VCL4- 19, 22, 24, 27, 30, 32, 36			

- Weight 1.5kg
- Storage Box 115 × 440 × 30mm

NEW



TOOL SETS

SPANNERS

STRIKING FACE WRENCHES

HOOK SPANNERS

DX2000 TOOLS  
HEXAGON KEY WRENCHES

HEXAGON KEY WRENCHES

TORQUE WRENCHES

CROWFOOT WRENCHES

SOCKETS

OTHER TOOLS



Please do not use the product of this mark with the power tool including the impact wrench.

# 3/4" (19.0mm) - Drive

## VC6 Crowfoot Wrench, Spanner Type

Code	mm	B mm	b mm	H mm	L mm	effective length ℓ mm	Weight g	Price ¥
VC6030	30	55	36	19	89	55	380	11,100
VC6032	32	60	36	19	90	55	410	11,600
VC6036	36	66	38	19	93	55	450	13,000
VC6041	41	74	38	19	106	65	560	14,400
VC6046	46	82	42	19	110	65	650	16,300
VC6050	50	90	42	19	113	65	720	17,300
VC6055	55	96	45	19	117	65	780	18,200

• Nickel Chrome Plating

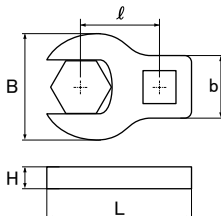

NEW

Hand Tool



TOOL SETS

SPANNERS

STRIKING FACE WRENCHES

HOOK SPANNERS

DX2000 TOOLS  
HEXAGON KEY WRENCHES

HEXAGON KEY WRENCHES

TORQUE WRENCHES

CROWFOOT WRENCHES

SOCKETS

OTHER TOOLS



Please do not use the product of this mark with the power tool including the impact wrench.



# Sockets

**Socket**



	VS2	VS3	VK3	VS4	VJR4	VK4	VF4	VS6
Insertion angle mm	6.3	9.5		12.7				19.0
Shape	6point	12point	12point Deep	12point	6point	12point Deep	12point Spline	12point
Width across flat mm								
4	●							
4.5	●							
5	●							
5.5	●							
6	●	●						
7	●	●						
8	●	●	●	●	●	●		
9	●	●	●	●	●	●		
10	●	●	●	●	●	●	●	
11	●	●	●	●	●	●		
12	●	●	●	●	●	●	●	
13	●	●	●	●	●	●	●	
14		●	●	●	●	●	●	
15		●	●	●	●	●	●	
16		●	●	●	●	●		
17		●	●	●	●	●	●	
18		●	●	●	●	●		
19		●	●	●	●	●	●	●
20		●	●	●	●	●		
21		●	●	●	●	●	●	●
22		●	●	●	●	●	●	●
23		●	●	●	●	●		
24				●	●	●	●	●
25						●		
26				●	●	●		●
27				●	●	●		●
28						●		
29				●		●		●
30				●	●	●		●
31						●		
32				●	●	●		●
35								●
36								●
38								●
41								●
46								●
50								●
54								●
55								●

**Hex Bit Socket**



	VX2	VX3	VX4
Insertion angle mm	6.3	9.5	12.7
Width across flat mm			
3	●	●	
4	●	●	●
5	●	●	●
6	●	●	●
8	●	●	●
10	●	●	●
12			●
14			●
17			●

# 1/4" (6.3mm) - Drive

## SD2 Socket Wrench Set

**34Pcs.**

Code **SD2340**

Price **¥12,800**

Set Contains

Socket (12point)	VS2- 4, 4.5, 5, 5.5, 6, 7, 8, 9, 10, 11, 13
Hexagon Socket	VX2- 3, 4, 5, 6, 8, 10
Driver Bit Socket	VD2- $\ominus 4$ , $\ominus 5.5$ , $\ominus 7$ VD2- $\oplus$ No.1, $\oplus$ No.2, $\oplus$ No.3, $\oplus$ No.4
Ratchet Handle	VR0200
Extension Bar	50mm, 100mm
Other Tools	Universal Joint, Sliding T-Handle, Driver Handle, Spin Disk
Hexagon Key Wrench	1.5, 2, 2.5

- Weight 900g
- Tool Box 110×200×35mm



TOOL SETS

SPANNERS

STRIKING FACE WRENCHES

HOOK SPANNERS

DX2000 TOOLS

HEXAGON KEY WRENCHES

HEXAGON KEY WRENCHES

TORQUE WRENCHES

CROWFOOT WRENCHES

SOCKETS

OTHER TOOLS

## VS2 Socket, Metric

Code		D <sub>1</sub> mm	D <sub>2</sub> mm	h mm	L mm	Weight g		Price ¥
VS2040	4	6.7	11.8	6	25	12	10	770
VS2045	4.5	7.4	11.8	8	25	12	10	770
VS2050	5	8	11.8	9	25	12	10	770
VS2055	5.5	8.7	11.8	9	25	12	10	770
VS2060	6	9.3	11.8	9	25	12	10	770
VS2070	7	10.5	11.8	9	25	13	10	770
VS2080	8	11.8	11.8	10	25	15	10	770
VS2090	9	12.6	12.6	10	25	15	10	770
VS2100	10	14	14	10	25	16	10	810
VS2110	11	15.8	15.8	10	25	22	10	810
VS2120	12	17	17	10	25	25	10	810
VS2130	13	17	17	10	25	25	10	860

- Nickel Chrome Plating

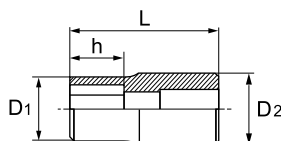

## VX2 Hexagon Socket, Metric

Code		D mm	ℓ mm	L mm	Weight g		Price ¥
VX2003	3	12	6	25	11	-	830
VX2004	4	12	6.5	25	12	-	830
VX2005	5	12	7.5	25	13	-	830
VX2006	6	12	8	25	14	-	830
VX2008	8	12	9	25	15	-	830
VX2010	10	12	10	25	18	-	830

- Body : Nickel Chrome Plating
- Hex : Black Oxide Finish

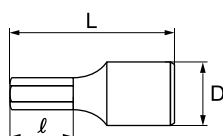

# 1/4" (6.3mm) - Drive

## VD2 Driver Bit Socket

Code	⊕ ⊖	D <sub>mm</sub>	L <sub>mm</sub>	Weight <sub>g</sub>		Price ¥
VD2001	⊕ No.1	12	25	10	-	870
VD2002	⊕ No.2	12	25	11	-	870
VD2003	⊕ No.3	12	25	12	-	870
VD2004	⊕ No.4	12	25	13	-	870
VD2040	⊖ 4	12	25	9	-	870
VD2055	⊖ 5.5	12	25	10	-	870
VD2070	⊖ 7	12	25	11	-	870

• Nickel Chrome Plating

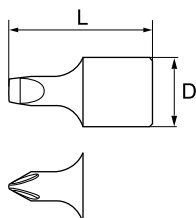

TOOL SETS

SPANNERS

STRIKING FACE WRENCHES

HOOK SPANNERS

DX2000 TOOLS  
HEXAGON KEY WRENCHES

HEXAGON KEY WRENCHES

TORQUE WRENCHES

CROWFOOT WRENCHES

SOCKETS

OTHER TOOLS

## VR2 Ratchet Handle

Code	D <sub>mm</sub>	T <sub>mm</sub>	L <sub>mm</sub>	Ratcheting Angle	Weight <sub>g</sub>		Price ¥
VR0211	24.5	18	125	9°	110	1	5,300

- Square Drive : Parkerizing
- Body : Nickel Chrome Plating
- Rubber grip

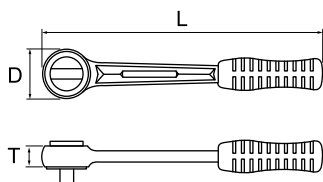

## VE2 Extension Bar

Code	D <sub>mm</sub>	L <sub>mm</sub>	Weight <sub>g</sub>		Price ¥
VE0275	12.5	75	35	-	1,180
VE0215	12.5	150	70	-	1,350

• Nickel Chrome Plating

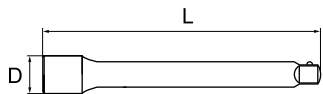

## VH2 Spinner Handle

Code	D <sub>mm</sub>	L <sub>mm</sub>	Weight <sub>g</sub>		Price ¥
VH0215	13	140	85	-	2,570

- Nickel Chrome Plating
- Insert a crossbar to the hole of the spinner handle to utilize as a T-handled wrench.

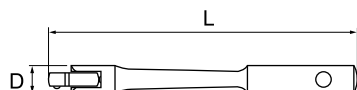

## 1/4" (6.3mm) - Drive

### VT2 Sliding T-Handle

Code	H mm	d mm	L mm	Weight g		Price ¥
VT0211	24	6	115	70	-	1,980

- Nickel Chrome Plating
- Adjust a position of a square drive for quick turning and final tightening.

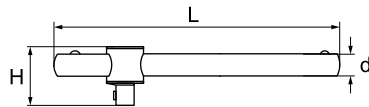

Hand Tool



### VU2 Universal Joint

Code	D mm	L mm	Weight g		Price ¥
VU0200	14	35	70	-	3,000

- Nickel Chrome Plating

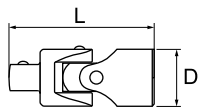

Hand Tool



### VG2 Driver Handle

Code	L mm	Weight g		Price ¥
VG0214	150	65	-	1,700

- Plastic grip

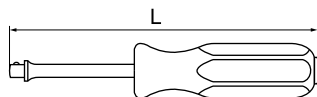

Hand Tool



### VB2 Cross Bar

Code	D mm	L mm	Weight g		Price ¥
VB0212	6	125	30	-	320

- Nickel Chrome Plating
- Insert a crossbar through the hole of the spinner handle and utilize as a T-handled wrench.

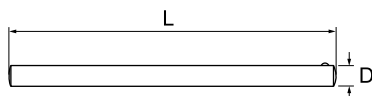

Hand Tool



TOOL SETS

SPANNERS

STRIKING FACE WRENCHES

HOOK SPANNERS

DX2000 TOOLS  
HEXAGON KEY WRENCHES

HEXAGON KEY WRENCHES

TORQUE WRENCHES

CROWFOOT WRENCHES

SOCKETS

OTHER TOOLS



Please do not use the product of this mark with the power tool including the impact wrench.

**ASAHI**  
TOOLS

## 3/8" (9.5mm) - Drive VO3 Socket Wrench Set

**19Pcs.**

Code **VO3121** Price **¥27,500**

Set Contains

Socket (12point)	VS3- 6, 7, 8, 9, 10, 11, 12, 13, 14, 17, 19, 21, 22
Ratchet Handle	LVR3180 <b>LIGHTTOOL®</b>
Extension Bar	VE0375 (75mm), 0315 (150mm)
Universal Joint	VU0300
Spinner Handle	VH0319 (228mm)
Speed Disk	VQ0300

- Weight 1870g
- Tool Box 105 × 290 × 60mm



VO3121

**19Pcs.**

Code **VO3122** Price **¥27,800**

Set Contains

Socket (12point)	VS3- 6, 7, 8, 9, 10, 11, 12, 13, 14, 17, 19, 21, 22
Ratchet Handle	VRL3180 <b>Revowave®</b>
Extension Bar	VE0375 (75mm), 0315 (150mm)
Universal Joint	VU0300
Spinner Handle	VH0319 (228mm)
Speed Disk	VQ0300

- Weight 1950g
- Tool Box 105 × 290 × 60mm



VO3122

TOOL SETS

SPANNERS

STRIKING FACE WRENCHES

HOOK SPANNERS

DX2000 TOOLS  
HEXAGON KEY WRENCHES

HEXAGON KEY WRENCHES

TORQUE WRENCHES

CROWFOOT WRENCHES

SOCKETS

OTHER TOOLS





Please do not use the product of this mark with the power tool including the impact wrench.

**ASAHI**  
TOOLS

# 3/8" (9.5mm) - Drive

## VS3 Socket, Metric

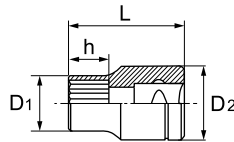

Code	 mm	D <sub>1</sub> mm	D <sub>2</sub> mm	h mm	L mm	Weight g		Price ¥
VS3060	6	10	17	9	26	22	10	770
VS3070	7	11	17	9	26	22	10	770
VS3080	8	12	18	9	26	20	10	820
VS3090	9	13	18	9	26	20	10	820
VS3100	10	14.5	18	9	26	20	10	820
VS3110	11	16	18	10	26	20	10	830
VS3120	12	18	18	10	26	20	10	830
VS3130	13	19	19	11	26	30	10	830
VS3140	14	20	20	11	26	40	10	830
VS3150	15	21	21	12	26	50	10	900
VS3160	16	23	23	12	26	50	10	900
VS3170	17	24	24	12	26	54	10	900
VS3180	18	25	25	12	26	55	10	930
VS3190	19	26	26	12	26	60	10	930
VS3200	20	28	28	13	28	75	10	980
VS3210	21	29	29	13	28	80	10	980
VS3220	22	30	27	13	28	74	10	1,100
VS3230	23	32	32	14	30	90	10	1,100

• Nickel Chrome Plating



TOOL SETS  
SPANNERS  
STRIKING FACE WRENCHES  
HOOK SPANNERS  
DX2000 TOOLS  
HEXAGON KEY WRENCHES  
HEXAGON KEY WRENCHES  
TORQUE WRENCHES  
CROWFOOT WRENCHES  
SOCKETS  
OTHER TOOLS

## VK3 Deep Socket, Metric

Code	 mm	D <sub>1</sub> mm	D <sub>2</sub> mm	h mm	L mm	Weight g		Price ¥
VK3080	8	12	17	8	55	59	-	1,780
VK3090	9	13.5	17.5	9	55	54	-	1,780
VK3100	10	14.5	18	11	55	55	-	1,780
VK3110	11	15.5	18	12	55	58	-	1,780
VK3120	12	17	18	13	55	59	-	1,780
VK3130	13	18.5	18.5	13	55	60	-	1,820
VK3140	14	19.5	18.5	14	55	62	-	1,820
VK3150	15	21	19	15	55	67	-	1,760
VK3160	16	22	19.5	15	55	71	-	1,760
VK3170	17	23	20	15	55	71	-	1,910
VK3180	18	24.5	20.5	16	55	82	-	2,140
VK3190	19	26	21	16	55	89	-	2,140
VK3200	20	27	21.5	17	55	96	-	2,140
VK3210	21	28.5	22	18	65	112	-	2,140
VK3220	22	30	22.5	18	65	113	-	2,280
VK3230	23	31	23	18	65	114	-	2,280

• Nickel Chrome Plating

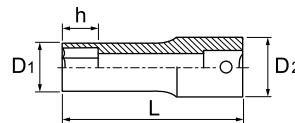

Please do not use the product of this mark with the power tool including the impact wrench.



## 3/8" (9.5mm) - Drive

### VX3 Hex Bit Socket, Metric

Code	mm	D mm	ℓ mm	L mm	Weight g	Price ¥
VX3003	3	18	22	48	30	10 950
VX3004	4	18	22	48	35	10 950
VX3005	5	17	26	52	31	10 970
VX3006	6	17	26	52	38	10 1,020
VX3008	8	19	26	52	50	10 1,090
VX3010	10	19	26	52	59	10 1,210

- Body : Nickel Chrome Plating
- Hex : Black Oxide Finish ( ~ 3006 )  
Decorative Chromium Plating(3008 ~ )

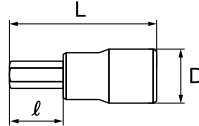

### VD3 Driver Bit Socket

Code	+	-	D mm	L mm	Weight g	Price ¥
VD3001	+	No.1	18	48	40	- 1,250
VD3002	+	No.2	18	48	40	- 1,250
VD3005	-	5	18	48	35	- 1,280
VD3006	-	6	18	48	35	- 1,280

- Body : Nickel Chrome Plating
- Bit : Parkerizing

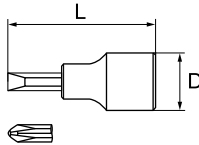

### VR3 Ratchet Handle

Code	D mm	T mm	L mm	Ratcheting Angle	Weight g	Price ¥
VR0319	34	15	204	9°	330	1 5,800

- Square Drive : Cathodic Electrodeposition
- Body : Nickel Chrome Plating

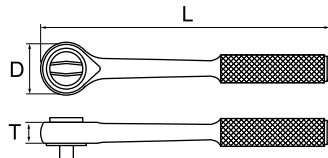

Please do not use the product of this mark with the power tool including the impact wrench.

## 3/8" (9.5mm) - Drive

### LVR3 Ratchet Handle

Code	D mm	T mm	L mm	Ratcheting Angle	Weight g		Price ¥
LVR3180	30	12.5	180	5°	178	1	6,400

- Square Drive : Parkerizing
- Body : Nickel Chrome Plating

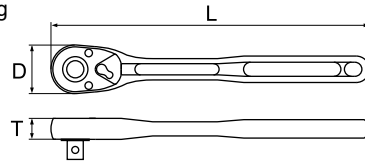

**LIGHTTOOL®**



### VRL3 Ratchet Handle

Code	D mm	T mm	L mm	Ratcheting Angle	Weight g		Price ¥
VRL3180	30	12.5	183	5°	270	1	6,600

- Square Drive : Parkerizing
- Body : Nickel Chrome Plating

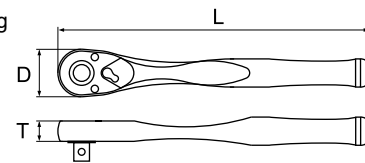

**Revowave®**



### VQ3 Speed Disk

Code	D mm	T mm	Weight g		Price ¥
VQ0300	35	3	11	-	330

- Nickel Chrome Plating

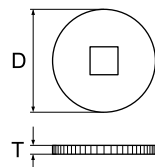

Attach it to a ratchet handle for fast-turning work.

## 3/8" (9.5mm) - Drive

### VE3 Extension Bar

Code	D <sub>mm</sub>	L <sub>mm</sub>	Weight <sub>g</sub>		Price <sub>¥</sub>
VE0375	18	75	80	-	1,350
VE0315	18	150	150	-	1,620

- Nickel Chrome Plating

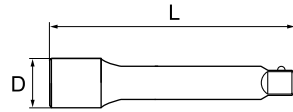

Hand Tool



### VEB3 Wobble Extension Bar

Code	D <sub>mm</sub>	L <sub>mm</sub>	Weight <sub>g</sub>		Price <sub>¥</sub>
VEB330	19	300	210	-	3,980

- Nickel Chrome Plating

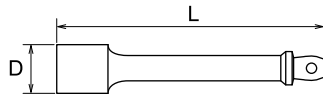

Hand Tool



Designed to be used at an angle off-axis to the screw by 10 degrees.

### VH3 Spinner Handle

Code	D <sub>mm</sub>	B <sub>mm</sub>	L <sub>mm</sub>	Weight <sub>g</sub>		Price <sub>¥</sub>
VH0319	22	14.5	228	250	-	4,370

- Nickel Chrome Plating

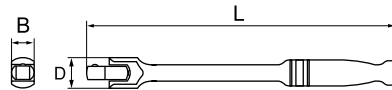

Hand Tool



TOOL SETS

SPANNERS

STRIKING FACE WRENCHES

HOOK SPANNERS

DX2000 TOOLS  
HEXAGON KEY WRENCHES

HEXAGON KEY WRENCHES

TORQUE WRENCHES

GROUND FOOT WRENCHES

SOCKETS

OTHER TOOLS



Please do not use the product of this mark with the power tool including the impact wrench.

**ASAHI**  
TOOLS

## 3/8" (9.5mm) - Drive

### VT3 Sliding T-Handle

Code	H mm	d mm	L mm	Weight g		Price ¥
VT0320	32	11	200	190	-	2,260

• Nickel Chrome Plating

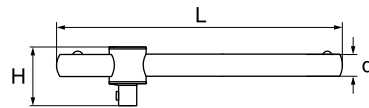

Adjust a position of a square drive for quick turning and final tightening.

### VTL3 T-Shape Speed Handle, Separate Type

Code	L <sub>1</sub> mm	D <sub>1</sub> mm	L <sub>2</sub> mm	D <sub>2</sub> mm	L <sub>3</sub> mm	Weight g		Price ¥
VTL0300	269	22	200	16	340	450	2	5,150

• Nickel Chrome Plating

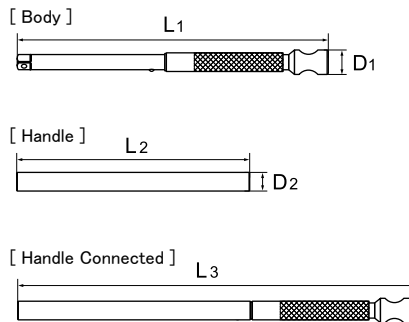

The handle can be stored in the body, so it takes up less storage space than existing T-shaped handles, making it convenient to carry around.

The quick-turn collar enables speedy work. The handle slides for use in either T or L configuration, depending on work requirements.

### VU3 Universal Joint

Code	D mm	L mm	Weight g		Price ¥
VU0300	18	54	100	-	3,100

• Nickel Chrome Plating

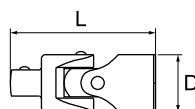

Please do not use the product of this mark with the power tool including the impact wrench.

## 3/8" (9.5mm) - Drive

### VA3 Adaptor

Code	mm × mm	D mm	L mm	Weight g	Price ¥
VA3020	9.5 × 6.3	18	26	30	-
VA3040	9.5 × 12.7	17	30	33	-

- Nickel Chrome Plating

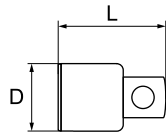

TOOL SETS

SPANNERS

STRIKING FACE WRENCHES

HOOK SPANNERS

DX2000 TOOLS  
HEXAGON KEY WRENCHES

HEXAGON KEY WRENCHES

TORQUE WRENCHES

CROWFOOT WRENCHES

SOCKETS

OTHER TOOLS

### VP3 Plug Socket

Code	mm	A mm	D mm	L mm	Weight g	Price ¥
VP0321	21	19	28	70	120	-

- Nickel Chrome Plating
- The internal rubber surface secures plugs firmly.

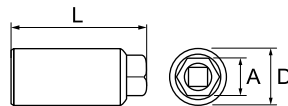

### VB3 Cross Bar

Code	D mm	L mm	Weight g	Price ¥
VB0315	8	150	60	-

- Nickel Chrome Plating

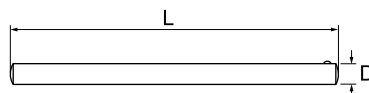

Please do not use the product of this mark with the power tool including the impact wrench.

**ASAHI**  
TOOLS

# 1/2" (12.7mm) - Drive

## VO4 Socket Wrench Set, 12point, Metric

**13Pcs.**

Code **VO4100** Price **¥25,500**



VO4100

Set Contains	
Socket (12point)	VS4- 10, 12, 13, 14, 15, 17, 19, 21, 23, 26
Ratchet Handle	LVR4252 <b>LIGHTTOOL</b> <sup>®</sup>
Sliding T-Handle	VT0425
Extension Bar	VE0415 (150mm)

- Weight 2.5kg
- Tool Box 105 × 290 × 60mm

**13Pcs.**

Code **VO4101** Price **¥25,500**



VO4101

Set Contains	
Socket (12point)	VS4- 8, 10, 11, 12, 13, 14, 17, 19, 22, 24
Ratchet Handle	LVR4252 <b>LIGHTTOOL</b> <sup>®</sup>
Sliding T-Handle	VT0425
Extension Bar	VE0415 (150mm)

- Weight 2.5kg
- Tool Box 105 × 290 × 60mm

**17Pcs.**

Code **VO4131** Price **¥31,700**



VO4131

Set Contains	
Socket (12point)	VS4- 8, 10, 11, 12, 13, 14, 17, 19, 21, 22, 24, 26, 27
Ratchet Handle	LVR4252 <b>LIGHTTOOL</b> <sup>®</sup>
Spinner Handle	VH0430 (300mm)
Extension Bar	VE0415 (150mm)
Cross Bar	VB0425 (250mm)

- Weight 3.6kg
- Tool Box 130 × 350 × 55mm

**20Pcs.**

Code **VO4150** Price **¥43,300**



VO4150

Set Contains	
Socket (12point)	VS4- 9, 10, 12, 13, 14, 15, 16, 17, 18, 19, 21, 23, 26, 29, 32
Ratchet Handle	LVR4252 <b>LIGHTTOOL</b> <sup>®</sup>
Spinner Handle	VH0438 (380mm)
Extension Bar	VE0415 (150mm)
Sliding T-Handle	VT0425
Cross Bar	VB0425 (250mm)

- Weight 4.7kg
- Tool Box 150 × 450 × 55mm

TOOL SETS

SPANNERS

STRIKING FACE WRENCHES

HOOK SPANNERS

DX2000 TOOLS  
HEXAGON KEY WRENCHES

HEXAGON KEY WRENCHES

TORQUE WRENCHES

CROWFOOT WRENCHES

SOCKETS

OTHER TOOLS



Please do not use the product of this mark with the power tool including the impact wrench.

# 1/2" (12.7mm) - Drive

## VO4 Socket Wrench Set, 12point, Metric

**20Pcs.**

Code **VO4151** Price **¥43,900**



Hand Tool

12point

Set Contains	
Socket (12point)	VS4- 10, 11, 12, 13, 14, 17, 19, 21, 22, 23, 24, 26, 27, 30, 32
Ratchet Handle	LVR4252 <b>LIGHTTOOL®</b>
Spinner Handle	VH0438 (380mm)
Extension Bar	VE0415 (150mm)
Sliding T-Handle	VT0425
Cross Bar	VB0425 (250mm)

- Weight 4.8kg
- Tool Box 150 × 450 × 55mm



VO4151

**14Pcs.**

Code **VO4200** Price **¥26,300**

Set Contains	
Socket (12point)	VS4- 10, 12, 13, 14, 15, 17, 19, 21, 23, 26
Ratchet Handle	VRL4250 <b>Revowave®</b>
Sliding T-Handle	VT0425
Extension Bar	VE0415 (150mm)
Speed Disk	VQ0400

- Weight 2.6kg
- Tool Box 105 × 290 × 60mm



VO4200

**14Pcs.**

Code **VO4201** Price **¥26,300**

Set Contains	
Socket (12point)	VS4- 8, 10, 11, 12, 13, 14, 17, 19, 22, 24
Ratchet Handle	VRL4250 <b>Revowave®</b>
Sliding T-Handle	VT0425
Extension Bar	VE0415 (150mm)
Speed Disk	VQ0400

- Weight 2.6kg
- Tool Box 105 × 290 × 60mm



VO4201

**18Pcs.**

Code **VO4231** Price **¥32,600**

Set Contains	
Socket (12point)	VS4- 8, 10, 11, 12, 13, 14, 17, 19, 21, 22, 24, 26, 27
Ratchet Handle	VRL4250 <b>Revowave®</b>
Spinner Handle	VH0430 (300mm)
Extension Bar	VE0415 (150mm)
Cross Bar	VB0425 (250mm)
Speed Disk	VQ0400

- Weight 3.7kg
- Tool Box 130 × 350 × 55mm



VO4231

TOOL SETS

SPANNERS

STRIKING FACE WRENCHES

HOOK SPANNERS

DX2000 TOOLS  
HEXAGON KEY WRENCHES

HEXAGON KEY WRENCHES

TORQUE WRENCHES

CROWFOOT WRENCHES

SOCKETS

OTHER TOOLS



Please do not use the product of this mark with the power tool including the impact wrench.

**ASAHI**  
TOOLS



# 1/2" (12.7mm) - Drive

## VO4 Socket Wrench Set, 12point, Metric

**21Pcs.**

Code **VO4250** Price **¥43,900**

Set Contains

Socket (12point)	VS4- 9, 10, 12, 13, 14, 15, 16, 17, 18, 19, 21, 23, 26, 29, 32
Ratchet Handle	VRL4250 <b>Revo wave</b>
Spinner Handle	VH0438 (380mm)
Extension Bar	VE0415 (150mm)
Sliding T-Handle	VT0425
Cross Bar	VB0425 (250mm)
Speed Disk	VQ0400

- Weight 4.8kg
- Tool Box 150 × 450 × 55mm



VO4250

**21Pcs.**

Code **VO4251** Price **¥44,700**

Set Contains

Socket (12point)	VS4- 10, 11, 12, 13, 14, 17, 19, 21, 22, 23, 24, 26, 27, 30, 32
Ratchet Handle	VRL4250 <b>Revo wave</b>
Spinner Handle	VH0438 (380mm)
Extension Bar	VE0415 (150mm)
Sliding T-Handle	VT0425
Cross Bar	VB0425 (250mm)
Speed Disk	VQ0400

- Weight 4.9kg
- Tool Box 150 × 450 × 55mm



VO4251

## VJS4 Socket Wrench Set, 6point, Metric

**13Pcs.**

Code **VJS4100** Price **¥25,200**

Set Contains

Socket (6point)	VJR4-10, 12, 13, 14, 15, 17, 19, 21, 23, 26
Ratchet Handle	LVR4252 <b>LIGHTTOOL</b>
Sliding T-Handle	VT0425
Extension Bar	VE0415 (150mm)

- Weight 2.5kg
- Tool Box 105 × 290 × 60mm



VJS4100

**13Pcs.**

Code **VJS4101** Price **¥25,200**

Set Contains

Socket (6point)	VJR4-8, 10, 11, 12, 13, 14, 17, 19, 22, 24
Ratchet Handle	LVR4252 <b>LIGHTTOOL</b>
Sliding T-Handle	VT0425
Extension Bar	VE0415 (150mm)

- Weight 2.5kg
- Tool Box 105 × 290 × 60mm



VJS4101

TOOL SETS

SPANNERS

STRIKING-FACE WRENCHES

HOOK SPANNERS

DX2000 TOOLS

HEXAGON KEY WRENCHES

HEXAGON KEY WRENCHES

TORQUE WRENCHES

GROWFOOT WRENCHES

SOCKETS

OTHER TOOLS



Please do not use the product of this mark with the power tool including the impact wrench.

# 1/2" (12.7mm) - Drive

## VJS4 Socket Wrench Set, 6point, Metric

**17Pcs.**

Code **VJS4131** Price **¥32,800**



Set Contains	
Socket (6point)	VJR4-8, 10, 11, 12, 13, 14, 17, 19, 21, 22, 24, 26, 27
Ratchet Handle	LVR4252 <b>LIGHTOOL</b> <sup>®</sup>
Spinner Handle	VH0430 (300mm)
Extension Bar	VE0415 (150mm)
Cross Bar	VB0425 (250mm)

- Weight 3.6kg
- Tool Box 130 × 350 × 55mm



VJS4131

**20Pcs.**

Code **VJS4151** Price **¥43,600**

Set Contains	
Socket (6point)	VJR4-10, 11, 12, 13, 14, 17, 19, 21, 22, 23, 24, 26, 27, 30, 32
Ratchet Handle	LVR4252 <b>LIGHTOOL</b> <sup>®</sup>
Spinner Handle	VH0438 (380mm)
Extension Bar	VE0415 (150mm)
Sliding T-Handle	VT0425
Cross Bar	VB0425 (250mm)

- Weight 4.8kg
- Tool Box 150 × 450 × 55mm



VJS4151

**14Pcs.**

Code **VJS4200** Price **¥26,000**

Set Contains	
Socket (6point)	VJR4-10, 12, 13, 14, 15, 17, 19, 21, 23, 26
Ratchet Handle	VRL4250 <b>Revo wave</b> <sup>®</sup>
Sliding T-Handle	VT0425
Extension Bar	VE0415 (150mm)
Speed Disk	VQ0400

- Weight 2.6kg
- Tool Box 105 × 290 × 60mm



VJS4200

**14Pcs.**

Code **VJS4201** Price **¥26,000**

Set Contains	
Socket (6point)	VJR4-8, 10, 11, 12, 13, 14, 17, 19, 22, 24
Ratchet Handle	VRL4250 <b>Revo wave</b> <sup>®</sup>
Sliding T-Handle	VT0425
Extension Bar	VE0415 (150mm)
Speed Disk	VQ0400

- Weight 2.6kg
- Tool Box 105 × 290 × 60mm



VJS4201

TOOL SETS

SPANNERS

STRIKING FACE WRENCHES

HOOK SPANNERS

DX2000 TOOLS  
HEXAGON KEY WRENCHES

HEXAGON KEY WRENCHES

TORQUE WRENCHES

CROWFOOT WRENCHES

SOCKETS

OTHER TOOLS



Please do not use the product of this mark with the power tool including the impact wrench.

**ASAHI**  
TOOLS

## 1/2" (12.7mm) - Drive

### VJS4 Socket Wrench Set, 6point, Metric

**18Pcs.**

Code **VJS4231** Price **¥33,600**

Set Contains

Socket (6point)	VJR4-8, 10, 11, 12, 13, 14, 17, 19, 21, 22, 24, 26, 27
Ratchet Handle	VRL4250 <b>Revowave</b>
Spinner Handle	VH0430 (300mm)
Extension Bar	VE0415 (150mm)
Cross Bar	VB0425 (250mm)
Speed Disk	VQ0400

- Weight 3.7kg
- Tool Box 130 × 350 × 55mm



VJS4231

**21Pcs.**

Code **VJS4251** Price **¥44,400**

Set Contains

Socket (6point)	VJR4-10, 11, 12, 13, 14, 17, 19, 21, 22, 23, 24, 26, 27, 30, 32
Ratchet Handle	VRL4250 <b>Revowave</b>
Spinner Handle	VH0438 (380mm)
Extension Bar	VE0415 (150mm)
Sliding T-Handle	VT0425
Cross Bar	VB0425 (250mm)
Speed Disk	VQ0400

- Weight 4.9kg
- Tool Box 150 × 450 × 55mm



VJS4251

### VFS4 Socket Wrench Set, Spline

**13Pcs.**

Code **VFS4100** Price **¥22,700**

Set Contains

Hybrid Socket	VF4- 10, 12, 13, 14, 15, 17, 19, 21, 22, 24
Ratchet Handle	LVR4252 <b>LIGHTTOOL</b>
Extension Bar	VE0415(150mm)
Sliding T-Handle	VT0425(250mm)

- Weight 2.3kg
- Tool Box 105 × 290 × 60mm



### VX4 Hex Bit Socket Wrench Set, Metric

**12Pcs.**

Code **VX4000** Price **¥26,100**

Set Contains

Hexagon Socket	VX4- 4, 5, 6, 8, 10, 12, 14, 17
Driver Bit Socket	VD4- ⊖6, ⊕No.2
Ratchet Handle	LVR4252 <b>LIGHTTOOL</b>
Extension Bar	VE0415 (150mm)

- Weight 2.4kg
- Tool Box 132 × 364 × 45mm



TOOL SETS

SPANNERS

STRIKING FACE WRENCHES

HOOK SPANNERS

DX2000 TOOLS

HEXAGON KEY WRENCHES

HEXAGON KEY WRENCHES

TORQUE WRENCHES

GROWFOOT WRENCHES

SOCKETS

OTHER TOOLS





Please do not use the product of this mark with the power tool including the impact wrench.

**ASAHI**  
TOOLS

# 1/2" (12.7mm) - Drive

## VS4 Socket, Metric



Code	 mm	D <sub>1</sub> mm	D <sub>2</sub> mm	h mm	L mm	Weight g		Price ¥
VS4080	8	13	22	12.5	36	42	10	920
VS4090	9	13.6	23	11	37	42	10	920
VS4100	10	15	22	11	36	42	10	920
VS4110	11	16	23	7	37	44	10	920
VS4120	12	17	22	11	36	50	10	920
VS4130	13	19	22	12	36	47	10	920
VS4140	14	20	23	10	37	46	10	920
VS4150	15	21	22	10	38	54	10	960
VS4160	16	23	23	15	37	60	10	960
VS4170	17	24	23	13.5	38	63	10	960
VS4180	18	25	24	13	38	64	10	1,010
VS4190	19	26	24	15	38	69	10	1,010
VS4210	21	28	26	17	38	81	5	1,060
VS4220	22	30	26	17	38	85	5	1,060
VS4230	23	32	26	15	38	99	5	1,160
VS4240	24	32	27	16	38	93	5	1,160
VS4260	26	34	28	18	38	110	5	1,230
VS4270	27	36	29	18	42	127	5	1,320
VS4290	29	38.5	28	23	44	180	5	1,540
VS4300	30	40	33	21	44	183	5	1,650
VS4320	32	42	35	21	44	201	5	1,850

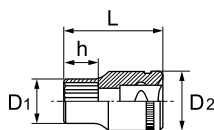

• Nickel Chrome Plating



## VJR4 Socket, Metric

Code	 mm	D <sub>1</sub> mm	D <sub>2</sub> mm	h mm	L mm	Weight g		Price ¥
VJR4080	8	12	23	11	37	50	-	930
VJR4100	10	15	22	13	36	43	-	930
VJR4110	11	16.5	22	12	36	45	-	930
VJR4120	12	17	22	12.5	36	45	-	930
VJR4130	13	19	22	11	36	48	-	930
VJR4140	14	20	22	13	36	60	-	930
VJR4150	15	21	23	14	37	60	-	1,010
VJR4160	16	22.5	24	14	38	66	-	1,010
VJR4170	17	24	23	14	38	66	-	1,010
VJR4180	18	25	23	14	38	61	-	1,010
VJR4190	19	26	24	18	38	68	-	1,010
VJR4210	21	28	26	17	38	84	-	1,100
VJR4220	22	30	26	16	38	93	-	1,100
VJR4230	23	32	26	15	38	103	-	1,180
VJR4240	24	32	27	17	38	99	-	1,210
VJR4260	26	34	28	18	38	105	-	1,270
VJR4270	27	36	29	19	44	150	-	1,410
VJR4300	30	40	33	21	44	192	-	1,780
VJR4320	32	42	35	21	44	214	-	1,940



• Nickel Chrome Plating

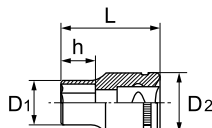

TOOL SETS

SPANNERS

STRIKING FACE WRENCHES

HOOK SPANNERS

DX2000 TOOLS  
HEXAGON KEY WRENCHES

HEXAGON KEY WRENCHES

TORQUE WRENCHES

GRIP FOOT WRENCHES

SOCKETS

OTHER TOOLS



Please do not use the product of this mark with the power tool including the impact wrench.

# Hybrid Socket

Due to the unique spline shape interior, a socket is compatible with metric or inch-sized bolts, hexalobe screws, and square bolts.

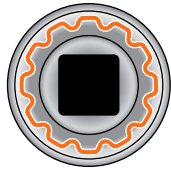
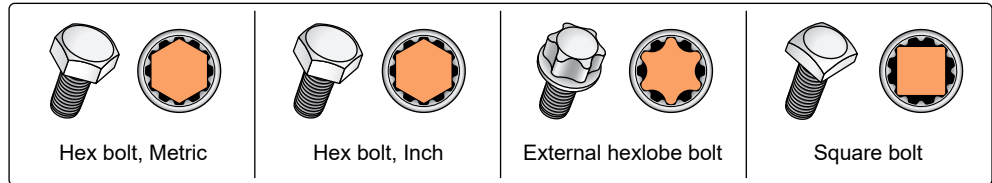

Unique spline shape

Bolt Compatibility Table

Code	VF4100	VF4120	VF4130	VF4140	VF4150	VF4170	VF4190	VF4210	VF4220	VF4240
ボルト mm	10	12	13	14	15	17	19	21	22	24
inch			1/2				3/4	13/16	7/8	15/16
E type							E24		E28	
mm					13				19	

(For reference)

## VF4 Socket, Metric

Code	mm	D1 mm	D2 mm	h mm	L mm	Weight g	Price ¥
VF4100	10	15.5	22	14	38	48	640
VF4120	12	18	22	14	38	51	640
VF4130	13	19.2	22	14	38	51	640
VF4140	14	20.5	22	14	38	51	640
VF4150	15	22	21	14	38	50	640
VF4170	17	24	22	14	38	58	650
VF4190	19	26	24	15	38	66	740
VF4210	21	29	26	15	38	86	860
VF4220	22	30	26	15	38	88	860
VF4240	24	32	28	15	38	102	970

• Nickel Chrome Plating

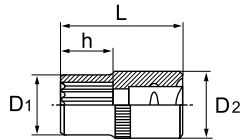



Please do not use the product of this mark with the power tool including the impact wrench.



# 1/2" (12.7mm) - Drive

## VK4 Deep Socket, Metric



Code	 mm	D <sub>1</sub> mm	D <sub>2</sub> mm	h mm	L mm	Weight g		Price ¥
VK4080	8	12.5	21	10	80	82	-	2,390
VK4090	9	13.5	21	10.5	80	86	-	2,390
VK4100	10	15	21	11.5	80	94	-	2,470
VK4110	11	16	21	13	80	93	-	2,470
VK4120	12	17.5	22	14.5	80	112	-	2,470
VK4130	13	19	22	16	80	117	-	2,550
VK4140	14	20	22	17	80	123	-	2,600
VK4150	15	21	22	18	80	130	-	2,710
VK4160	16	22.5	22.5	19	80	136	-	2,710
VK4170	17	24	23	21	80	143	-	2,720
VK4180	18	25	24	23	80	152	-	2,780
VK4190	19	26.5	24	23	80	152	-	2,780
VK4200	20	27.5	25	25	80	153	-	2,900
VK4210	21	28.5	25	25	80	167	-	2,900
VK4220	22	30	26	27	80	162	-	3,170
VK4230	23	31	26	27	80	195	-	3,320
VK4240	24	32.5	27	29	80	178	-	3,410
VK4250	25	33.5	27	29	80	200	-	3,610
VK4260	26	35	28	29	80	200	-	3,740
VK4270	27	36	28	30	80	212	-	3,890
VK4280	28	37	29	30	80	212	-	4,250
VK4290	29	38.5	30	30	80	253	-	4,250
VK4300	30	39.5	31	30	80	258	-	4,370
VK4310	31	41	32	30	80	278	-	4,700
VK4320	32	42	33	30	80	293	-	4,700

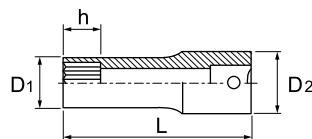

• Nickel Chrome Plating



## VX4 Hex Bit Socket, Metric

Code	 mm	D mm	ℓ mm	L mm	Weight g		Price ¥
VX4004	4	23	22	60	60	10	1,190
VX4005	5	23	22	60	65	10	1,190
VX4006	6	23	22	60	75	10	1,190
VX4008	8	23	22	60	90	10	1,250
VX4010	10	23	22	60	110	10	1,310
VX4012	12	24	22	60	120	10	1,360
VX4014	14	24	22	60	130	10	1,410
VX4017	17	28	30	70	200	10	1,580



- Body : Nickel Chrome Plating
- Hex : Black Oxide Finish ( ~ 4006 )  
Cathodic Electrodeposition (4008 ~ )

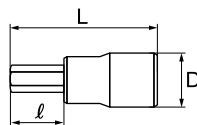

Please do not use the product of this mark with the power tool including the impact wrench.

# 1/2" (12.7mm) - Drive

## VD4 Driver Bit Socket

Code	⊕ ⊖	D mm	L mm	Weight g		Price ¥
VD4002	⊕ No.2	23	60	65	-	1,360
VD4003	⊕ No.3	23	60	85	-	1,500
VD4004	⊕ No.4	23	60	90	-	1,600
VD4006	⊖ 6	23	60	75	-	1,500
VD4008	⊖ 8	23	60	95	-	1,600
VD4010	⊖ 10	23	60	95	-	1,670

- Body : Nickel Chrome Plating
- Bit : Parkerizing

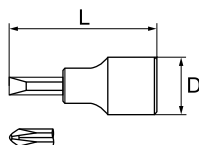

## LVR4 Ratchet Handle

Code	D mm	T mm	L mm	Ratcheting Angle	Weight g		Price ¥
LVR4252	38.5	16.5	250	5°	400	1	7,400

- Square Drive : Parkerizing
- Body : Nickel Chrome Plating

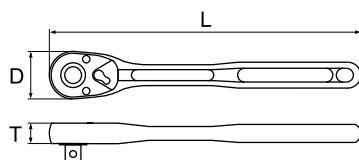

LIGHTTOOL®



## VRL4 Ratchet Handle

Code	D mm	T mm	L mm	Ratcheting Angle	Weight g		Price ¥
VRL4250	38.5	16.5	250	5°	520	1	7,900

- Square Drive : Parkerizing
- Body : Nickel Chrome Plating

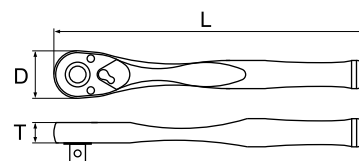

Revowave®



## VQ4 Speed Disk

Code	D mm	T mm	Weight g		Price ¥
VQ0400	41	3	17	-	370

- Nickel Chrome Plating

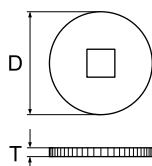

Attach it to a ratchet handle for fast-turning work.



Please do not use the product of this mark with the power tool including the impact wrench.

ASAHI TOOLS

TOOL SETS

SPANNERS

STRIKING FACE WRENCHES

HOOK SPANNERS

DX2000 TOOLS  
HEXAGON KEY WRENCHES

HEXAGON KEY WRENCHES

TORQUE WRENCHES

CROWFOOT WRENCHES

SOCKETS

OTHER TOOLS



## 1/2" (12.7mm) - Drive

### VE4 Extension Bar

Code	D mm	L mm	Weight g		Price ¥
VE0475	24	75	140	-	1,850
VE0415	24	150	260	5	2,010
VE0425	24	250	400	2	2,910

- Nickel Chrome Plating

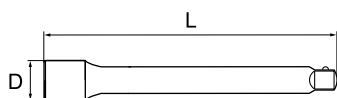

### VEB4 Wobble Extension Bar

Code	D mm	L mm	Weight g		Price ¥
VEB438	24	380	440	2	5,200

- Nickel Chrome Plating



Designed to be used at an angle off-axis to the screw by 10 degrees.

### VH4 Spinner Handle

Code	D mm	B mm	L mm	Weight g		Price ¥
VH0430	31	21	300	630	2	5,500
VH0438	31	21	380	770	2	6,200

- Nickel Chrome Plating

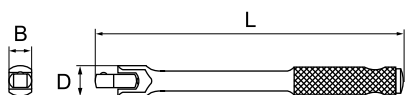

Insert a crossbar to the hole of the spinner handle to utilize as a T-handled wrench.

### VT4 Sliding T-Handle

Code	H mm	d mm	L mm	Weight g		Price ¥
VT0425	42	14	250	380	2	2,900

- Nickel Chrome Plating

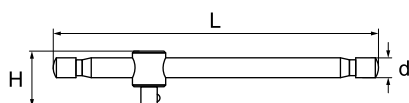

Adjust a position of a square drive for quick turning and final tightening.



Please do not use the product of this mark with the power tool including the impact wrench.

# 1/2" (12.7mm) - Drive

## VTL4 T-Shape Speed Handle, Separate Type

Code	L <sub>1</sub> mm	D <sub>1</sub> mm	L <sub>2</sub> mm	D <sub>2</sub> mm	L <sub>3</sub> mm	Weight g		Price ¥
VTL0400	320	26	230	20	375	800	2	5,670

• Nickel Chrome Plating

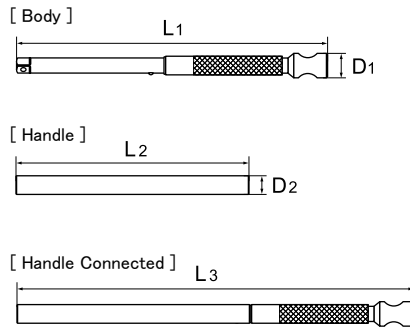

The handle can be stored in the body, so it takes up less storage space than existing T-shaped handles, making it convenient to carry around.

The quick-turn collar enables speedy work.

The handle slides for use in either T or L configuration, depending on work requirements.



## VU4 Universal Joint

Code	D mm	L mm	Weight g		Price ¥
VU0400	25	69	130	5	3,500

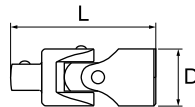
• Nickel Chrome Plating





## VA4 Adaptor

Code	 mm x mm	D mm	L mm	Weight g		Price ¥
VA4030	12.7 × 9.5	23	35	50	-	2,050
VA4060	12.7 × 19.0	25	40	115	-	3,070

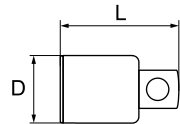
• Nickel Chrome Plating



## VP4 Plug Socket

Code	 mm	A mm	D mm	L mm	Weight g		Price ¥
VP0421	21	22	27	68	145	-	2,260

- Nickel Chrome Plating
- The internal rubber surface secures plugs firmly

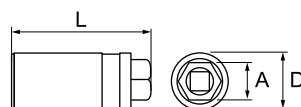

Please do not use the product of this mark with the power tool including the impact wrench.

# 1/2" (12.7mm) - Drive

## VL4 Offset Handle

Code	d mm	H mm	L mm	Weight g		Price ¥
VL0428	16	57	280	500	5	2,750

• Nickel Chrome Plating

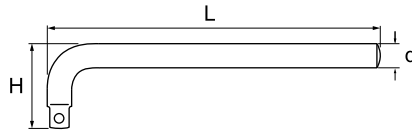

Hand Tool



## VN4 Speeder

Code	H mm	L mm	Weight g		Price ¥
VN0440	93	415	660	5	5,500

• Nickel Chrome Plating

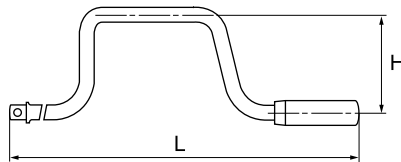

Hand Tool



For quick turning

## VB4 Cross Bar

Code	D mm	L mm	Weight g		Price ¥
VB0425	12	250	220	-	650

• Nickel Chrome Plating

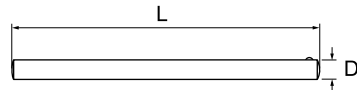

Hand Tool



Insert a crossbar through the hole of the spinner handle and utilize as a T-handled wrench.

TOOL SETS

SPANNERS

STRIKING FACE WRENCHES

HOOK SPANNERS

DX2000 TOOLS  
HEXAGON KEY WRENCHES

HEXAGON KEY WRENCHES

TORQUE WRENCHES

CROWFOOT WRENCHES

SOCKETS

OTHER TOOLS



Please do not use the product of this mark with the power tool including the impact wrench.

# 3/4" (19.0mm) - Drive

## VO6 Socket Wrench Set, 12point, Metric

**12Pcs.**

Code **VO6080** Price **¥75,400**



Set Contains

Socket (12point)	VS6- 26, 29, 32, 35, 38, 41, 46, 50
Ratchet Handle	VR0650
Sliding T-Handle	VT0650
Extension Bar	VE0620 (200mm) , VE0640 (400mm)

- Weight 10.2kg
- Tool Box 145 × 510 × 80mm



VO6080

**12Pcs.**

Code **VO6081** Price **¥75,400**

Set Contains

Socket (12point)	VS6- 24, 27, 30, 32, 36, 41, 46, 50
Ratchet Handle	VR0650
Sliding T-Handle	VT0650
Extension Bar	VE0620 (200mm) , VE0640 (400mm)

- Weight 10.2kg
- Tool Box 145 × 510 × 80mm



VO6081

## VS6 Socket, Metric

Code		D <sub>1</sub> mm	D <sub>2</sub> mm	h mm	L mm	Weight g		Price ¥
VS6190	19	30	35	18	50	200	5	2,380
VS6210	21	31	36	14.5	51	223	5	2,380
VS6220	22	32	35	17.5	51	196	5	2,380
VS6240	24	34	35	16	50	194	5	2,380
VS6260	26	36	35	20	52	195	5	2,480
VS6270	27	38	36	25	52	221	5	2,490
VS6290	29	41	38	29	55	250	5	2,820
VS6300	30	42	36	29	56	260	5	2,820
VS6320	32	43	36	26	56	276	5	2,920
VS6350	35	48	41	26	58	400	2	3,030
VS6360	36	50	42	24	58	399	2	3,130
VS6380	38	52	40	26	65	440	2	4,160
VS6410	41	55	40	28	65	490	2	4,540
VS6460	46	61	43	30	70	590	2	4,940
VS6500	50	68	42	38	70	785	2	6,200
VS6550	55	75	48	42	76	993	-	8,900

- Nickel Chrome Plating

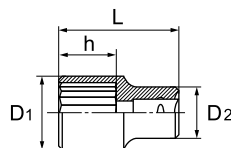

TOOL SETS

SPANNERS

STRIKING FACE WRENCHES

HOOK SPANNERS

DX2000 TOOLS  
HEXAGON KEY WRENCHES

HEXAGON KEY WRENCHES

TORQUE WRENCHES

GROUNDFOOT WRENCHES

SOCKETS

OTHER TOOLS



Please do not use the product of this mark with the power tool including the impact wrench.

## 3/4" (19.0mm) - Drive

### VR6 Ratchet Handle

Code	D mm	T mm	L mm	Ratcheting Angle	Weight g		Price ¥
VR0650	65	34.5	504	8°	1,800	1	17,400

- Square Drive : Cathodic Electrodeposition
- Body : Nickel Chrome Plating

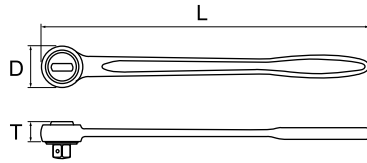

### VE6 Extension Bar

Code	D mm	L mm	Weight g		Price ¥
VE0620	35	200	580	3	4,060
VE0640	35	400	1,100	5	7,100

- Nickel Chrome Plating

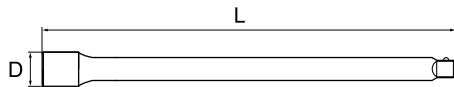

### VH6 Spinner Handle

Code	D mm	B mm	L mm	Weight g		Price ¥
VH0646	42	29	460	1,660	-	15,300

- Nickel Chrome Plating

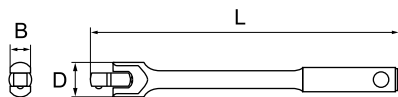

### VT6 Sliding T-Handle

Code	H mm	d mm	L mm	Weight g		Price ¥
VT0650	60	20	490	1,500	1	6,600

- Nickel Chrome Plating

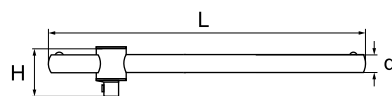

Adjust a position of a square drive for quick turning and final tightening.



Please do not use the product of this mark with the power tool including the impact wrench.

## 3/4" (19.0mm) - Drive

### VU6 Universal Joint

Code	D mm	L mm	Weight g		Price ¥
VU0600	40	106	555	1	9,100

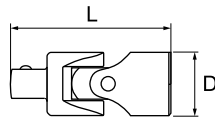

• Nickel Chrome Plating



Hand Tool



### VA6 Adaptor

Code	 mm x mm	D mm	L mm	Weight g		Price ¥
VA6040	19.0 x 12.7	36	52	224	-	5,200

• Nickel Chrome Plating

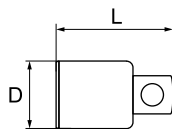

Hand Tool



### VL6 Offset Handle

Code	d mm	H mm	L mm	Weight g		Price ¥
VL0630	25	87	330	1,400	5	6,500

• Nickel Chrome Plating

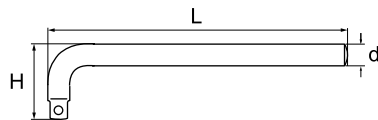

Hand Tool



TOOL SETS

SPANNERS

STRIKING FACE WRENCHES

HOOK SPANNERS

DX2000 TOOLS  
HEXAGON KEY WRENCHES

HEXAGON KEY WRENCHES

TORQUE WRENCHES

CROWFOOT WRENCHES

SOCKETS

OTHER TOOLS



Please do not use the product of this mark with the power tool including the impact wrench.

**ASAHI**  
TOOLS

# Impact Sockets

## Socket



US3 USL3 US4 USL4 US6 USL6 US8 USL8 US10

Insertion angle mm	9.5	12.7	19.0	25.4	38.1
--------------------	-----	------	------	------	------

Shape	Long	Long	Long	Long
-------	------	------	------	------

Width across flat					
-------------------	--	--	--	--	--

7		●	●					
8	●	●	●					
9	●		●					
10	●	●	●	●				
11	●							
12	●	●	●	●				
13	●	●	●	●				
14	●	●	●	●				
15	●		●					
16	●		●					
17	●	●	●	●	●		●	●
18	●						●	
19	●	●	●	●	●	●	●	●
20	●							
21	●	●	●	●	●	●	●	●
22	●	●	●	●	●	●	●	●
23	●		●	●	●	●	●	
24			●	●	●	●	●	●
26			●	●	●	●	●	●
27			●	●	●	●	●	●
29			●		●	●	●	
30			●	●	●	●	●	●
32			●	●	●	●	●	●
35			●		●	●	●	●
36			●		●	●	●	●
38				●	●	●	●	
41				●	●	●	●	
46				●	●	●	●	
50				●		●	●	●
54						●	●	●
55				●		●	●	●
58						●	●	
60						●	●	●
63						●		
65						●		●
67						●		
70						●		●
71						●		
75						●		●
80						●		●
85						●		●
90						●		●
95						●		●
100								●
105								●
110								●
115								●
120								●

## Hex Bit Socket



UX3 UX4 UXX6 UXX8 UXX10

Insertion angle mm	9.5	12.7	19.0	25.4	38.1
--------------------	-----	------	------	------	------



Width across flat					
-------------------	--	--	--	--	--

3	●				
4	●				
5	●	●			
6	●	●			
8	●	●			
9.5		●			
10	●	●	●		
12	●	●	●		
12.7		●			
14		●	●	●	
17		●	●	●	
19		●	●	●	
22			●	●	●
24				●	●
27				●	●
32				●	●
36					●



# 3/8" (9.5mm) - Drive

## US3 Impact Socket, Metric



Code	 mm	D <sub>1</sub> mm	D <sub>2</sub> mm	h mm	L mm	Weight g		Price ¥
US0308	8	13	19	5	25	27	-	1,280
US0309	9	14.5	19	6	25	28	-	1,280
US0310	10	16	19	7	25	30	-	1,280
US0311	11	17.5	19	7	25	31	-	1,280
US0312	12	19	19	8	25	33	-	1,280
US0313	13	20	20	8	27	41	-	1,280
US0314	14	21.5	20	8	27	43	-	1,280
US0315	15	23	20	9	27	45	-	1,390
US0316	16	24	20	9	27	46	-	1,430
US0317	17	25.5	20	10	27	48	-	1,430
US0318	18	27	20	12	30	57	-	1,560
US0319	19	28	20	12	30	57	-	1,680
US0320	20	30	20	12	32	63	-	1,680
US0321	21	31	20	12	32	73	-	1,680
US0322	22	32	20	12	32	71	-	1,710
US0323	23	34	20	12	32	83	-	1,730

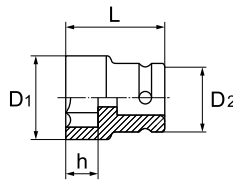

• Manganese Phosphate Treatment



## USL3 Long Impact Socket, Metric

Code	 mm	D <sub>1</sub> mm	D <sub>2</sub> mm	h mm	L mm	Weight g		Price ¥
USL0307	7	11.5	19	6	55	49	-	2,040
USL0308	8	12.5	19	7	55	54	-	2,040
USL0310	10	15.5	19	8	55	63	-	2,040
USL0312	12	18.5	20	9	55	78	-	2,040
USL0313	13	20	20	9	55	85	-	2,170
USL0314	14	21	20	11	55	86	-	2,170
USL0317	17	25	20	11	55	90	-	2,200
USL0319	19	27	20	12	55	90	-	2,400
USL0321	21	30	20	21	55	110	-	2,520
USL0322	22	32	20	21	55	120	-	2,710



• Manganese Phosphate Treatment

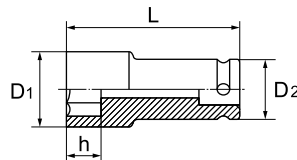

TOOL SETS  
SPANNERS  
STRIKING FACE WRENCHES  
HOOK SPANNERS  
DX2000 TOOLS  
HEXAGON KEY WRENCHES  
HEXAGON KEY WRENCHES  
TORQUE WRENCHES  
CROWFOOT WRENCHES  
SOCKETS  
OTHER TOOLS

## 3/8" (9.5mm) - Drive

### UX3 Impact Hex Bit Socket, Metric

Code	mm	D mm	ℓ mm	L mm	Weight g		Price ¥
UX3003	3	19	12	50	33	-	1,710
UX3004	4	19	15	50	34	-	1,710
UX3005	5	19	17	50	35	-	1,850
UX3006	6	19	18	50	37	-	1,850
UX3008	8	20	23	50	52	-	1,970
UX3010	10	20	27	50	62	-	1,970
UX3012	12	20	30	50	74	-	2,150

• Manganese Phosphate Treatment

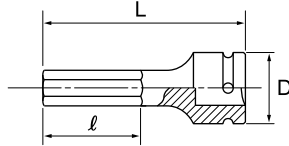

Impact Tool



### UE3 Extension Bar

Code	L mm	Weight g		Price ¥
UE0307	75	70	-	3,130
UE0310	100	90	-	3,350

• Manganese Phosphate Treatment



Impact Tool



### UJ3 Universal Joint

Code	L mm	Weight g		Price ¥
UJ0300	51	75	-	6,800

• Manganese Phosphate Treatment

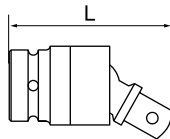

Impact Tool



### UA3 Adaptor

Code	mm x mm	L mm	Weight g		Price ¥
UA0304	9.5 x 12.7	34	55	-	3,290

• Manganese Phosphate Treatment

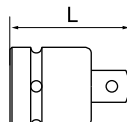

Impact Tool



TOOL SETS

SPANNERS

STRIKING FACE WRENCHES

HOOK SPANNERS

DX2000 TOOLS  
HEXAGON KEY WRENCHES

HEXAGON KEY WRENCHES

TORQUE WRENCHES



CROWFOOT WRENCHES

SOCKETS

OTHER TOOLS

# 1/2" (12.7mm) - Drive

## US4 Impact Socket, Metric

Code	 mm	D <sub>1</sub> mm	D <sub>2</sub> mm	h mm	L mm	Weight g		Price ¥
US0407	7	14	25	6	35	60	-	1,300
US0408	8	15	25	6	35	60	-	1,300
US0409	9	16	25	6	35	75	-	1,300
US0410	10	17.5	25	7	35	65	-	1,390
US0412	12	20.5	25	8	35	70	-	1,390
US0413	13	21	25	8	35	70	-	1,390
US0414	14	23	27	9	38	95	-	1,390
US0415	15	24.5	27	10	38	100	-	1,480
US0416	16	25.5	27	10	38	100	-	1,480
US0417	17	27	27	10	38	110	-	1,480
US0419	19	30	28	12	40	130	-	1,610
US0421	21	33	28	14	40	145	-	1,610
US0422	22	34	28	14	43	160	-	1,610
US0423	23	35	28	14	43	165	-	1,790
US0424	24	36.5	28	14	43	170	-	1,790
US0426	26	39	28	15	45	185	-	1,920
US0427	27	40	28	15	45	200	-	2,400
US0429	29	43	28	16	45	210	-	2,690
US0430	30	44	28	18	47	220	-	2,830
US0432	32	47	28	18	47	240	-	2,970
US0435	35	50	36	20	50	340	-	3,360
US0436	36	51	36	20	50	340	-	3,590

• Manganese Phosphate Treatment

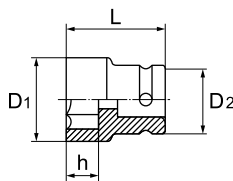

Impact Tool



6point



TOOL SETS

SPANNERS

STRIKING FACE WRENCHES

HOOK SPANNERS

DX2000 TOOLS  
HEXAGON KEY WRENCHES

HEXAGON KEY WRENCHES



TORQUE WRENCHES

CROWFOOT WRENCHES

SOCKETS

OTHER TOOLS

## USL4 Long Impact Socket, Metric

Code	 mm	D <sub>1</sub> mm	D <sub>2</sub> mm	h mm	L mm	Weight g		Price ¥
USL0410	10	14	24	15	60	75	-	2,080
USL0412	12	17	24	15	60	85	-	2,080
USL0413	13	18	24	15	60	90	-	2,080
USL0414	14	20	24	17	60	95	-	2,080
USL0417	17	24	24	17	60	120	-	2,080
USL0419	19	26	26	17	60	135	-	2,410
USL0421	21	28.5	26	17	60	155	-	2,500
USL0422	22	30	27	20	60	165	-	2,680
USL0423	23	31	28	20	60	185	-	2,680
USL0424	24	33	28	20	60	200	-	2,680
USL0426	26	35	28	20	80	270	-	2,950
USL0427	27	37	28	20	80	315	-	3,100
USL0430	30	41	28	23	80	270	-	3,620
USL0432	32	43	36	23	80	390	-	4,010

• Zinc Plating

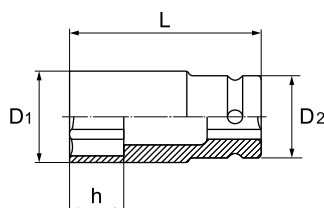

Impact Tool



6point



## 1/2" (12.7mm) - Drive

### UX4 Impact Hex Bit Socket, Metric

Code	mm	D mm	ℓ mm	L mm	Weight g		Price ¥
UX4005	5	25	17	60	67	-	2,030
UX4006	6	25	18	60	70	-	2,030
UX4008	8	25	23	60	78	-	2,140
UX4009	9.5	27	27	68	108	-	2,140
UX4010	10	27	27	68	110	-	2,140
UX4012	12	27	30	68	123	-	2,250
UX4013	12.7	27	30	68	127	-	2,440
UX4014	14	28	40	78	159	-	2,440
UX4017	17	28	40	78	194	-	2,560
UX4019	19	28	40	78	222	-	3,340

• Manganese Phosphate Treatment

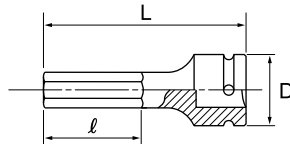

Impact Tool



### UE4 Extension Bar

Code	L mm	Weight g		Price ¥
UE0410	100	155	-	3,440
UE0415	150	220	-	4,270
UE0420	200	290	-	4,370
UE0425	250	355	-	4,530

• Manganese Phosphate Treatment



Impact Tool



### UJ4 Universal Joint

Code	L mm	Weight g		Price ¥
UJ0400	68	200	-	8,300

• Manganese Phosphate Treatment

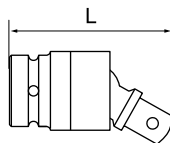

Impact Tool



### UA4 Adaptor

Code	mm × mm	L mm	Weight g		Price ¥
UA0403	12.7 × 9.5	36	65	-	3,410
UA0406	12.7 × 19.0	47	145	-	3,900

• Manganese Phosphate Treatment

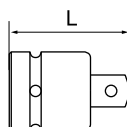

Impact Tool



TOOL SETS

SPANNERS

STRIKING FACE WRENCHES

HOOK SPANNERS

HEXAGON KEY WRENCHES

HEXAGON KEY WRENCHES

TORQUE WRENCHES

CROWFOOT WRENCHES

SOCKETS

OTHER TOOLS

## 3/4" (19.0mm) - Drive

### US6 Impact Socket, Metric

Code	mm	D <sub>1</sub> mm	D <sub>2</sub> mm	h mm	L mm	Weight g		Price ¥
US0617	17	27.5	36	10	48	195	-	2,920
US0619	19	30.5	37	12	48	220	-	2,920
US0621	21	33	37	13	50	240	-	2,920
US0622	22	34.5	37	14	50	245	-	2,920
US0623	23	36	37	14	50	260	-	3,020
US0624	24	38	38	14	53	300	-	3,020
US0626	26	40	38	15	53	310	-	3,100
US0627	27	42	38	15	53	325	-	3,100
US0629	29	44	38	16	55	360	-	3,470
US0630	30	46	38	16	55	380	-	3,470
US0632	32	49	38	18	55	385	-	3,470
US0635	35	53	38	22	58	450	-	3,870
US0636	36	54.5	38	22	58	470	-	3,870
US0638	38	58	38	23	60	550	-	4,820
US0641	41	62	44	23	60	655	-	5,100
US0646	46	68	44	26	60	790	-	7,000
US0650	50	73	44	28	70	900	-	9,500
US0655	55	78	54	30	74	1,310	-	14,500

• Manganese Phosphate Treatment

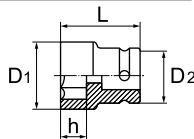

Impact Tool 6point



### USL6 Long Impact Socket, Metric

Code	mm	D <sub>1</sub> mm	D <sub>2</sub> mm	h mm	L mm	Weight g		Price ¥
USL0619	19	29	37	22	100	410	-	4,780
USL0621	21	32	37	22	100	450	-	4,780
USL0622	22	33	37	23	100	455	-	4,780
USL0623	23	34.5	37	23	100	490	-	4,980
USL0624	24	36	37	25	100	500	-	4,980
USL0626	26	40	38	25	100	580	-	5,400
USL0627	27	41	38	26	100	575	-	5,400
USL0630	30	44	38	26	100	570	-	6,200
USL0632	32	47.5	38	26	100	585	-	6,400
USL0635	35	51.5	38	26	100	610	-	7,000
USL0636	36	52	38	26	100	610	-	7,400
USL0638	38	55.5	38	28	100	680	-	8,500
USL0641	41	59	44	28	100	885	-	9,600
USL0646	46	65	44	31	100	930	-	12,000

• Manganese Phosphate Treatment

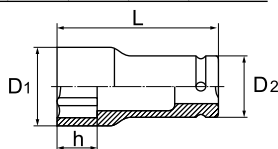

Impact Tool 6point



### UE6 Extension Bar

Code	L mm	Weight g		Price ¥
UE0610	100	400	-	6,600
UE0615	150	545	-	7,000
UE0620	200	700	-	7,900
UE0625	250	840	-	9,400

• Manganese Phosphate Treatment

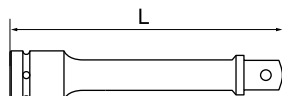

Impact Tool



TOOL SETS

SPANNERS

STRIKING FACE WRENCHES

HOOK SPANNERS

DX2000 TOOLS  
HEXAGON KEY WRENCHES

HEXAGON KEY WRENCHES

TORQUE WRENCHES

GROUNDFOOT WRENCHES

SOCKETS

OTHER TOOLS

## 3/4" (19.0mm) - Drive

### UXX6 Impact Hex Bit Socket, Metric

Code	Ø mm	B mm	D mm	ℓ mm	L mm	Weight g		Price ¥
UXX0610	10	22	44	32	90	540	-	7,100
UXX0612	12	22	44	32	90	545	-	7,100
UXX0614	14	22	44	32	90	555	-	7,100
UXX0617	17	22	44	32	90	570	-	7,100
UXX0619	19	22	44	32	90	580	-	7,100
UXX0622	22	22	44	32	90	620	-	7,100

- Body : Cathodic Electrodeposition
- Hex : Black Oxide Finish

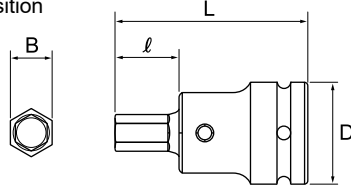

### 【 Exchange Bit 】

Code	Ø mm	D mm	L mm	Weight g		Price ¥
UXT0610	10	22	57	120	-	2,520
UXT0612	12	22	57	124	-	2,520
UXT0614	14	22	57	136	-	2,520
UXT0617	17	22	57	154	-	2,520
UXT0619	19	22	57	168	-	2,520
UXT0622	22	22	57	188	-	2,520

- For UXX6
- Black Oxide Finish

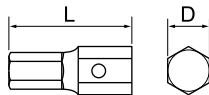

### UJ6 Universal Joint

Code	L mm	重量 g	箱入数	小売価格 ¥
UJ0600	112	800	-	12,800

- Manganese Phosphate Treatment

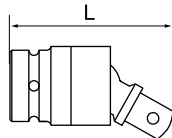

### UA6 Adaptor

Code	mm × mm	L mm	Weight g		Price ¥
UA0604	19.0 × 12.7	50	190	-	4,130
UA0604L	19.0 × 12.7	150	404	-	7,200
UA0608	19.0 × 25.4	61	990	-	6,500

- Manganese Phosphate Treatment

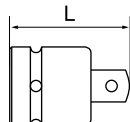

TOOL SETS

SPANNERS

STRIKING FACE WRENCHES

HOOK SPANNERS

DX2000 TOOLS  
HEXAGON KEY WRENCHES

HEXAGON KEY WRENCHES

TORQUE WRENCHES

CROWFOOT WRENCHES

SOCKETS

OTHER TOOLS

# 1" (25.4 mm) - Drive

## US8 Impact Socket, Metric

Code	mm	D <sub>1</sub> mm	D <sub>2</sub> mm	h mm	L mm	Weight g		Price ¥
US0817	17	31	48	12	57	400	-	5,500
US0819	19	33.5	48	12	57	400	-	5,500
US0821	21	36	48	13	57	420	-	5,500
US0822	22	37.5	48	14	57	425	-	5,500
US0823	23	38.5	48	14	57	430	-	5,500
US0824	24	40	48	14	57	440	-	5,500
US0826	26	43	49	15	57	470	-	5,500
US0827	27	45	49	15	60	520	-	5,500
US0829	29	47	49	16	60	530	-	5,500
US0830	30	49	49	16	62	580	-	5,500
US0832	32	52	52	18	62	575	-	5,500
US0835	35	55	52	19	62	765	-	5,900
US0836	36	56	52	19	62	780	-	5,900
US0838	38	59	52	26	68	790	-	6,600
US0841	41	63	52	26	68	790	-	7,000
US0846	46	69	52	26	72	960	-	8,900
US0850	50	73	52	28	75	1,000	-	10,900
US0854	54	78	60	31	80	1,400	-	12,600
US0855	55	80	60	31	80	1,450	-	14,000
US0858	58	83	60	31	80	1,450	-	16,400
US0860	60	86	60	32	80	1,560	-	18,900
US0863	63	90	60	34	80	1,550	-	20,200
US0865	65	92	60	36	85	1,800	-	22,600
US0867	67	95	60	37	85	1,800	-	29,700
US0870	70	97	60	40	90	2,000	-	31,900
US0871	71	98	60	40	90	2,420	-	34,800
US0875	75	103	60	44	95	2,200	-	37,800
US0880	80	110	60	48	100	2,460	-	49,900
US0885	85	116	66	51	105	2,920	-	57,000
US0890	90	122	66	54	110	3,250	-	68,500
US0895	95	135	80	57	115	3,270	-	76,600



Impact Tool 6point

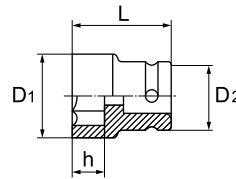

• Manganese Phosphate Treatment

## USL8 Long Impact Socket, Metric

Code	mm	D <sub>1</sub> mm	D <sub>2</sub> mm	h mm	L mm	Weight g		Price ¥
USL0817	17	30	49	20	100	760	-	8,400
USL0819	19	32	49	23	100	780	-	8,400
USL0821	21	35	49	23	100	800	-	8,400
USL0822	22	36	49	23	100	800	-	8,400
USL0824	24	38	49	25	100	800	-	8,400
USL0826	26	41	49	25	100	900	-	8,400
USL0827	27	42	49	26	100	900	-	8,400
USL0830	30	46	52	26	100	900	-	8,400
USL0832	32	48	52	26	100	940	-	8,400
USL0835	35	52	52	26	100	1,030	-	9,000
USL0836	36	54	52	30	100	1,070	-	9,000
USL0838	38	56	52	30	100	1,100	-	10,400
USL0841	41	59	52	35	100	1,100	-	11,800
USL0846	46	66	52	35	100	1,140	-	14,000
USL0850	50	70	52	35	100	1,300	-	18,300
USL0854	54	77	60	35	110	1,600	-	18,900
USL0855	55	78	60	35	110	1,600	-	21,400
USL0858	58	81.5	60	37	110	1,850	-	22,400
USL0860	60	84	60	37	110	1,950	-	26,700



Impact Tool 6point

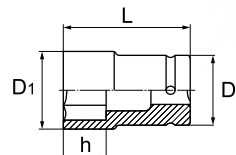

• Manganese Phosphate Treatment

TOOL SETS

SPANNERS

STRIKING FACE WRENCHES

HOOK SPANNERS

DX2000 TOOLS

HEXAGON KEY WRENCHES

TORQUE WRENCHES

CROWFOOT WRENCHES

SOCKETS

OTHER TOOLS



# 1" (25.4 mm) - Drive

## UE8 Extension Bar

Code	L mm	Weight g		Price ¥
UE0816	160	1,060	-	10,600
UE0820	200	1,300	-	11,800
UE0825	250	1,543	-	13,200
UE0830	300	1,800	-	13,800

- Manganese Phosphate Treatment



## UXX8 Impact Hex Bit Socket, Metric

Code	Ø mm	B mm	D mm	ℓ mm	L mm	Weight g		Price ¥
UXX0814	14	32	54	40	115	1,240	-	11,700
UXX0817	17	32	54	40	115	1,260	-	11,700
UXX0819	19	32	54	40	115	1,275	-	11,700
UXX0822	22	32	54	40	115	1,300	-	11,700
UXX0824	24	32	54	40	115	1,320	-	11,700
UXX0827	27	32	54	40	115	1,355	-	11,700
UXX0832	32	32	54	40	115	1,420	-	11,700

- Body : Cathodic Electrodeposition B
- Hex : Black Oxide Finish

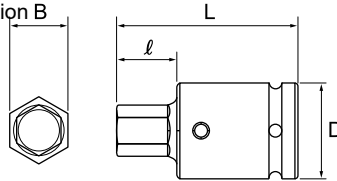

## 【 Exchange Bit 】

Code	Ø mm	D mm	L mm	Weight g		Price ¥
UXT0814	14	32	75	330	-	4,280
UXT0817	17	32	75	358	-	4,280
UXT0819	19	32	75	376	-	4,280
UXT0822	22	32	75	404	-	4,280
UXT0824	24	32	75	422	-	4,280
UXT0827	27	32	75	458	-	4,280
UXT0832	32	32	75	524	-	4,280

- For UXX6
- Black Oxide Finish

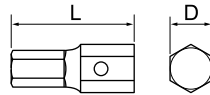

## UJ8 Universal Joint

Code	L mm	Weight g		Price ¥
UJ0800	128	1,300	-	18,900

- Manganese Phosphate Treatment

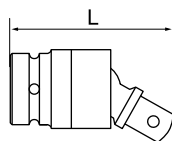

## 1" (25.4 mm) - Drive

### UA8 Adaptor

Code	mm × mm	L mm	Weight g		Price ¥
UA0806	25.4 × 19.0	64	430	-	6,500
UA0810	25.4 × 38.1	81	870	-	20,600

• Manganese Phosphate Treatment

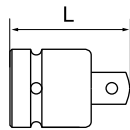

Impact Tool



## 1-1/2" (38.1 mm) - Drive

### US10 Impact Socket, Metric

Code	mm	D1 mm	D2 mm	h mm	L mm	Weight g		Price ¥
US1050	50	79	79	32	85	1,950	-	31,100
US1055	55	85	80	35	90	2,200	-	33,200
US1060	60	92	80	37	95	2,600	-	39,800
US1065	65	98	80	40	100	2,900	-	46,200
US1070	70	104	80	42	100	3,850	-	56,900
US1075	75	109	80	44	105	3,300	-	71,000
US1080	80	115	85	48	110	3,800	-	92,300
US1085	85	122	85	51	115	4,400	-	94,600
US1090	90	128	85	54	120	5,000	-	103,400
US1095	95	135	85	57	125	5,500	-	107,200
US1100	100	139	85	58	130	8,500	-	123,600
US1105	105	148	85	62	135	7,000	-	135,000
US1110	110	153	85	65	137	7,600	-	149,000
US1115	115	160	90	67	140	8,500	-	163,400
US1120	120	168	90	70	145	10,000	-	180,100

• Manganese Phosphate Treatment

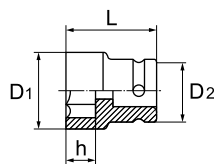

Impact Tool

6point



### UA10 Adaptor

Code	mm × mm	L mm	Weight g		Price ¥
UA1008	38.1 × 25.4	90	1,300	-	23,100

• Manganese Phosphate Treatment

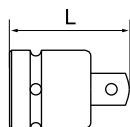

Impact Tool



TOOL SETS

SPANNERS

STRIKING FACE WRENCHES

HOOK SPANNERS

DX2000 TOOLS  
HEXAGON KEY WRENCHES

HEXAGON KEY WRENCHES

TORQUE WRENCHES

CROWFOOT WRENCHES

SOCKETS

OTHER TOOLS

# 1-1/2" (38.1mm) - Drive

## UXX10 Impact Hex Bit Socket, Metric

Code	Ø mm	B mm	D mm	ℓ mm	L mm	Weight g		Price ¥
UXX1022	22	27	83	35	125	2,600	-	38,900
UXX1024	24	27	83	35	125	2,620	-	38,900
UXX1027	27	27	83	35	125	2,690	-	38,900
UXX1032	32	36	83	37	127	3,280	-	42,200
UXX1036	36	36	83	37	127	3,350	-	42,200



- Body : Cathodic Electrodeposition
- Hex : Black Oxide Finish

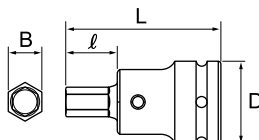

### 【 Exchange Bit 】

Code	Ø mm	D mm	L mm	Weight g		Price ¥
UXT1022	22	27	70	300	-	5,600
UXT1024	24	27	70	320	-	5,600
UXT1027	27	27	70	350	-	5,600
UXT1032	32	36	72	582	-	7,900
UXT1036	36	36	72	644	-	7,140

- For UXX10
- Black Oxide Finish

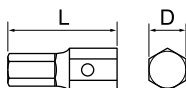

## UO UP O-Ring, Pin For Impact Socket



Impact Tool



O-Ring				Pin				Use With
Code	W mm	D mm	Price ¥	Code	B mm	L mm	Price ¥	
UO0300	2.4	14.8	210	UP0300	2.8	16.5	160	US3, USL3, UX3, UE3, UJ3, UA3
UO0400	3.5	20.2	220	UP0400	3.5	21	170	US4-7~13, USL4-10~22, UX4, UA4
UO0440	3.5	22.1	220	UP0440	3.5	24.5	170	US4-14~32, USL4-23~30, UE4, UJ4
UO0600	3.5	31.7	280	UP0460	3.5	32	170	US4-35~36, USL4-32
				UP0600	4	33.5	210	US6-17~38, USL6-19~38, UE6, UJ6, UA6
UO0660	3.5	37.7	280	UP0660	4	39	210	US6-41~50, USL6-41~46, UXX6
UO0800	5	44	300	UP0800	5	44.5	220	US6-55, US8-17~50, USL8-17~50, UE8, UJ8, UA8, UXX8
UO0850	3	49.6	300	UP0820	5	52	220	US8-54~80, USL8-54~60
UO0880	5.5	57.8	300	UP0840	5	58	220	US8-85~90
				UP1000	7	64	400	UA10
UO1000	5.5	69	610	UP1050	7	71	400	US10-50~110, UXX10
UO1100	5.5	79.4	610	UP0860	5	71	400	US8-95
				UP1100	7	81	400	US10-115~120

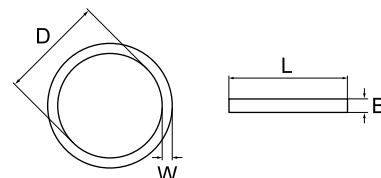

# AC Oilcan Cock

Code	D	H mm	Weight kg		Price ¥
AC6100	G2	232	1.4	10	29,200

• Zinc alloy (aluminum alloy flange)

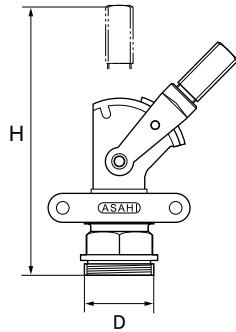

- Attach to an oil can, which is compatible for a JIS type G2 screw, and utilize as a cock.
- Please use for thickened noninflammable oil.
- It can be used for oil of non-flammable viscosity grade ISO VG32.
- Do not use for inflammable oils, paraffin oils, heavy fuel oils, petrol, chemicals, acid and alkaline solutions, solvents, aroma chemicals, paints, inks, and cooking oils. This product is not designed for the use of these materials.
- Please watch out for fire.
- The packing (large) is not included.

### [ How to use ]



Put on a cock to an oil tank.



Move the grip up or down to open or close the cock.

### AC6100 Parts List

No.	Parts	Code
①	Grip	TFACN
②	Handle	TFACH
③	Hex socket head cap bolt	
④	Phillips screw	TFACS
⑤	Spring	
⑥	Parts for fixing	TFACB
⑦	Bolt	
⑧	Nut	
⑨	Body / Nipple	TFAC6
⑩	Packing / Small	TFACPS
⑪	Packing / Large	TFACPL

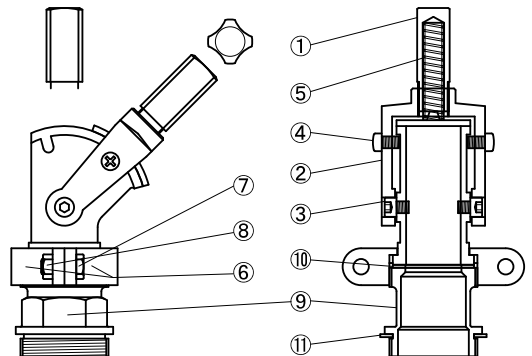

# AB Oilcan Spanner

Code	A mm	B mm	C mm	D mm	E mm	Weight g	Price ¥
	F mm	G mm	H mm	I mm	L mm		
AB5100	76	29	31	16.5	□25	1,080	10
	49	41	39	39	420		

• Black Oxide Finish

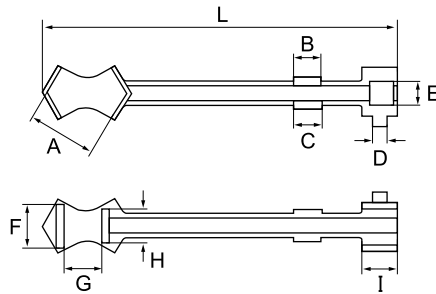

## 【 How to use 】

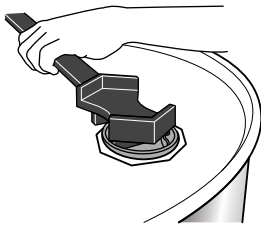

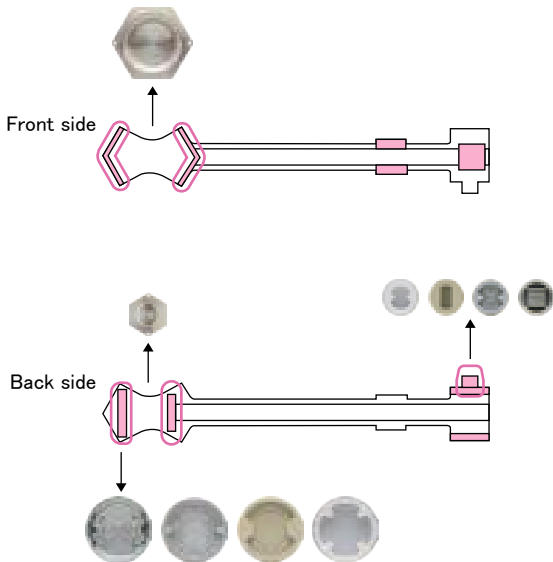

- For loosening or tightening a cap of a drum.
- Suitable for various kinds of caps.
- Insert an applicable size prong to a drum cap.
- Suitable for various kinds of caps.

## 【 Example of use 】



TOOL SETS  
 SPANNERS  
 STRIKING FACE WRENCHES  
 HOOK SPANNERS  
 DX2000 TOOLS  
 HEXAGON KEY WRENCHES  
 HEXAGON KEY WRENCHES  
 TORQUE WRENCHES  
 CROWFOOT WRENCHES  
 SOCKETS  
 OTHER TOOLS

## TB T-Handled Wrench, 6point, Metric



Code	 mm	D mm	T mm	L <sub>1</sub> mm	L <sub>2</sub> mm	d mm	Weight g		Price ¥
TB0007	7	12	11	110	100	8	85	-	940
TB0008	8	13	11	110	100	8	85	-	940
TB0009	9	14	11	110	100	8	90	-	1,210
TB0010	10	15.5	13	150	135	8	120	10	880
TB0011	11	17	15	150	135	10	195	10	1,210
TB0012	12	18	16	160	160	10	210	10	990
TB0013	13	19	17	160	160	10	210	10	1,080
TB0014	14	21	18	160	160	10	227	10	1,080
TB0017	17	24.5	20	180	180	11	295	10	1,130
TB0019	19	28	24	200	190	13	440	10	1,570
TB0021	21	30	25	210	200	13	465	10	1,610
TB0022	22	32	27	210	200	13	510	5	2,250
TB0024	24	34	29	235	220	14	650	5	2,420
TB0026	26	38	32	250	240	16	860	5	2,490
TB0027	27	38	33	250	240	16	850	-	3,840
TB0030	30	44	37	265	250	19	1,225	-	3,730
TB0032	32	44	39	270	250	19	1,300	-	4,090
TB0036	36	50	44	290	280	22	1,810	-	5,800
TB0041	41	58	45	310	300	25	2,800	-	5,900
TB0046	46	61	46	320	340	28	2,860	-	12,200
TB0050	50	66	56	360	380	28	3,420	-	17,700
TB0055	55	73	60	380	400	28	4,420	-	25,700

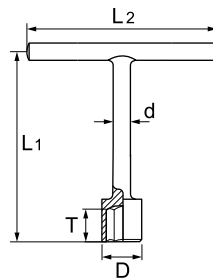

- Nickel Chrome Plating ( ~ 0041 )
- Cathodic Electrodeposition (0046 ~ )



## TW Long T-Handled Wrench, 6point, Metric

Code	 mm	D mm	T mm	L <sub>1</sub> mm	L <sub>2</sub> mm	d mm	Weight g		Price ¥
TW0008	8	13	11	250	200	8	180	10	1,290
TW0010	10	15.5	13	250	200	10	280	10	1,290
TW0012	12	18	16	250	200	12	395	10	1,390
TW0013	13	19	17	250	200	12	400	10	1,470
TW0014	14	21	18	270	220	12	440	10	1,580
TW0017	17	25	20	270	220	13	530	10	1,660
TW0019	19	28	23	300	250	14	700	5	2,010



- Nickel Chrome Plating

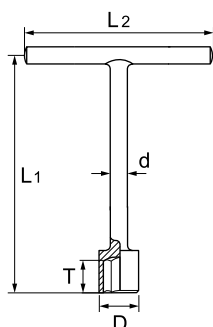

## BB T-Handle Wrench, Square Drive, Metric

Code	mm	D mm	T mm	L <sub>1</sub> mm	L <sub>2</sub> mm	d mm	Weight g	Price ¥
BB0008	8	16	12	76	80	6	80	1,590
BB0010	10	19	16	106	90	9	150	1,890
BB0012	12	23	18	112	110	9	190	2,040
BB0013	13	23	18	117	110	9	190	2,070
BB0014	14	26	20	126	130	10	215	2,640

• Nickel Chrome Plating

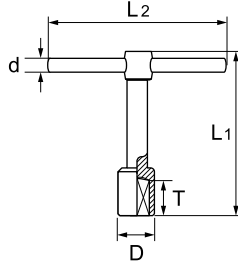

Square



## YB Y-Shape Wrench, 6point, Metric

Code	mm	d mm	D <sub>1</sub> mm	D <sub>2</sub> mm	D <sub>3</sub> mm	L mm	Weight g	Price ¥
YB0810	8×9×10	8	13	14	15.5	80	120	1,800
YB1014	10×12×14	10	15.5	18	21	85	185	2,010
YB1017	10×14×17	11	15.5	21	24.5	95	230	2,960
YB1217	12×14×17	11	18	21	24.5	95	270	2,620
YB1319	13×17×19	13	19	25	28	105	390	3,110
YB1419	14×17×19	13	21	25	28	105	400	3,020
YB1421	14×17×21	13	21	25	30	110	400	3,020
YB1923	19×21×23	13	28	30	33	120	550	4,610

• Nickel Chrome Plating

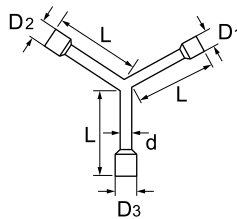

6point



## LB Tire Wrench, 6point, Metric

Code	mm	D mm	T mm	A mm	L mm	d mm	Weight g	Price ¥
LB0008	8	13	11	30	110	8	55	1,260
LB0010	10	15.5	13	30	180	8	90	930
LB0012	12	18	16	35	190	10	140	1,080
LB0013	13	19	17	37	190	10	150	1,020
LB0014	14	21	18	37	200	10	165	1,130
LB0017	17	24.5	20	45	220	11	225	1,130
LB0019	19	28	24	50	230	13	325	1,540
LB0021	21	30	25	50	250	13	370	1,590
LB0022	22	32	27	55	255	13	375	2,070
LB0024	24	34	29	57	265	14	460	2,240
LB0026	26	38	32	63	270	16	610	2,490
LB0027	27	38	33	63	275	16	610	3,280
LB0030	30	44	37	75	280	19	900	3,430
LB0032	32	44	39	75	280	19	850	3,860
LB0036	36	50	44	82	330	22	1,360	4,850
LB0041	41	58	46	90	350	25	1,550	5,300

• Nickel Chrome Plating ( ~ 0036)  
• Parkerizing (0041)



6point

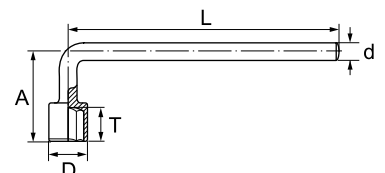

TOOL SETS

SPANNERS

STRIKING FACE WRENCHES

HOOK SPANNERS

DX2000 TOOLS  
HEXAGON KEY WRENCHES

HEXAGON KEY WRENCHES

TORQUE WRENCHES

GROUNDFOOT WRENCHES

SOCKETS

OTHER TOOLS



## PP Combination Plier

Code	Type	C mm	L mm	Weight g		Price ¥
PP0150	150	9	165	120	5	1,750
PP0200	200	11	203	350	5	2,220

• Nickel Chrome Plating

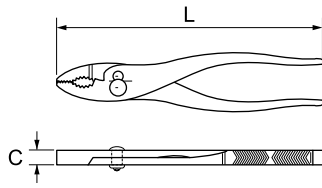

## PPW Water Pump Plier

Code	Max. mm	C mm	L mm	Weight g		Price ¥
PPW0250	47	10	252	340	1	3,380

• Nickel Chrome Plating

• Plastisol grip

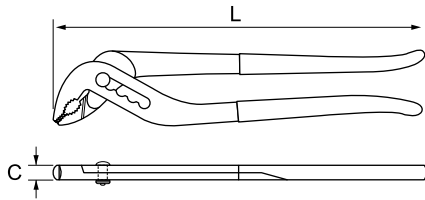

## HP Ball Pin Hammer

Code	Size lb	H mm	L mm	Weight g		Price ¥
HP0350	3/4	94	300	450	-	2,560
HP0450	1	102	320	590	10	2,560
HP0650	1-1/2	116	340	850	10	3,690

• Black Oxide Finish

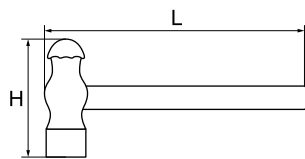

## HO Picking Hammer

Code	Size lb	H mm	L mm	Weight g		Price ¥
HO0100	1/4	107	390	110	10	2,490
HO0250	1/2	122	420	230	10	2,600

• Black Oxide Finish

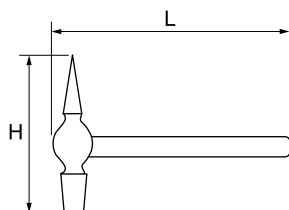

TOOL SETS

SPANNERS

STRIKING FACE WRENCHES

HOOK SPANNERS

DX2000 TOOLS  
HEXAGON KEY WRENCHES

HEXAGON KEY WRENCHES

TORQUE WRENCHES

CROWFOOT WRENCHES

SOCKETS

OTHER TOOLS

## KS Ratchet

Code	mm	C mm	T mm	d mm	L mm	Gear	Weight g		Price ¥
KS0017	17	36	35	13	220	12	330	2	7,900
KS0019	19	42	42	15	270	12	550	2	9,000
KS0021	21	42	42	15	270	12	550	2	9,000
KS0022	22	42	42	15	270	12	550	2	9,300
KS0024	24	49	48	18	325	12	880	2	9,800
KS0026	26	49	48	18	325	12	880	2	9,800
KS0027	27	49	48	18	325	12	880	2	11,400
KS0030	30	57	53	20	430	12	1,450	2	11,400
KS0032	32	57	53	20	430	12	1,450	2	11,400
KS0035	35	67	60	24	535	12	2,500	2	15,400
KS0036	36	67	60	24	535	12	2,500	2	15,700
KS0041	41	72	60	24	560	12	2,520	2	16,000
KS0046	46	82	65	26	590	14	3,400	2	21,500
KS0050	50	87	65	28	645	14	4,000	2	23,900
KS0055	55	97	65	30	760	16	5,500	-	36,200
KS0060	60	102	70	32	800	16	6,500	-	47,600
KS0065	65	113	75	34	910	16	7,000	-	69,000
KS0070	70	122	80	38.1	910	16	8,300	-	85,200
KS0075	75	130	80	38.1	965	16	9,000	-	113,700
KS0080	80	143	80	48.6	1,160	18	13,000	-	166,300

- Special Order (0060 ~ )
- Baking Finish

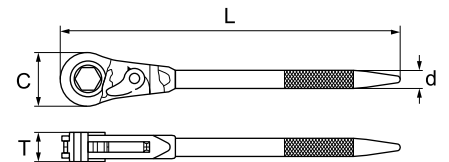

## KL Ratchet, Reversible Type

Code	mm	C mm	T mm	d mm	L mm	Gear	Weight g		Price ¥
KL0010	10	28	17	12	200	10	210	3	8,900
KL0012	12	36	20	13	245	10	350	3	9,200
KL0013	13	36	20	13	245	10	350	3	9,300
KL0014	14	42	24	15	295	10	550	3	9,800
KL0016	16	42	24	15	295	10	520	3	10,300
KL0017	17	49	28	16	385	10	850	3	11,700
KL0019	19	49	28	20	385	10	880	3	12,400
KL0022	22	57	30	22	400	10	1,400	3	14,800
KL0024	24	67	32	24	500	10	2,150	3	17,800
KL0025	25	67	32	24	500	10	2,300	3	17,800

- Cathodic Electrodeposition ( ~ 0019)
- Electrostatic coating (0022 ~ )

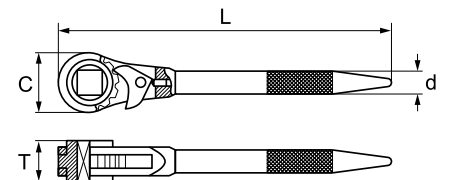

## KKL Ratchet

Code	mm	C mm	T mm	d mm	L mm	Gear	Weight g		Price ¥
KKL0013	13	36	20	13	220	12	320	3	9,300
KKL0016	16	42	24	15	270	12	520	3	10,300
KKL0019	19	49	28	18	325	12	860	3	12,400
KKL0022	22	57	30	20	430	12	1,400	3	14,800
KKL0025	25	67	32	24	535	12	2,300	3	17,800
KKL0028	28	72	33	24	555	14	2,500	3	26,900
KKL0032	32	82	37	26	590	14	3,270	3	27,200

- Baking Finish

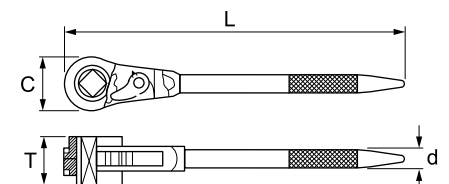

TOOL SETS

SPANNERS

STRIKING FACE WRENCHES

HOOK SPANNERS

DX2000 TOOLS

HEXAGON KEY WRENCHES

HEXAGON KEY WRENCHES

TORQUE WRENCHES

GROWFOOT WRENCHES

SOCKETS

OTHER TOOLS

## SMS Double Open End Spanner Set, Metric

**6Pcs.**

Code **SMS621H** Price **¥5,300**

Set Contains

Double Open End Spanner SM- 8×10, 11×13, 12×14, 14×17, 17×19, 22×24

- Weight 640g
- Number of boxes : 25
- Plastic Holder
- Nickel Chrome Plating



## SNT Combination Wrench Set, Metric

**6Pcs.**

Code **SNT110H** Price **¥4,600**

Set Contains

Combination Wrench 8, 10, 12, 13, 14, 17

- Weight 640g
- Number of boxes : 30
- Plastic Holder
- Nickel Chrome Plating



## SNT Offset Wrench Set, Metric

**6Pcs.**

Code **SNT621H** Price **¥10,800**

Set Contains

Offset Wrench 8×10, 11×13, 12×14, 14×17, 17×19, 22×24

- Weight 1,050g
- Number of boxes : 15
- Plastic Holder
- Nickel Chrome Plating



TOOL SETS

SPANNERS

STRIKING FACE WRENCHES

HOOK SPANNERS

DX2000 TOOLS  
HEXAGON KEY WRENCHES

HEXAGON KEY WRENCHES

TORQUE WRENCHES

GROWFOOT WRENCHES

SOCKETS

OTHER TOOLS

## SN Single End Spanner, Metric

Code	mm	C mm	T mm	L mm	Weight g		Price ¥
SN0010	10	23.4	4	105	20	20	450
SN0012	12	27.5	4.5	125	40	20	450
SN0013	13	30	4.5	130	45	20	450
SN0014	14	33	5	140	45	20	530
SN0017	17	38	5.5	160	85	20	590
SN0019	19	41.5	6.5	180	115	20	740
SN0022	22	47	7.5	195	140	20	930
SN0024	24	50	8.5	215	200	20	1,160
SN0026	26	56	9.5	235	250	20	1,210
SN0027	27	56	9.5	235	250	20	1,290
SN0030	30	65	10.5	275	320	10	1,580
SN0032	32	65	10.5	275	370	10	1,710
SN0035	35	74	12	305	550	10	2,640
SN0036	36	74	12	305	550	10	2,620
SN0038	38	74	12	305	550	10	3,520
SN0041	41	83	14	345	820	10	3,150
SN0046	46	92	16	385	1,200	5	4,700
SN0050	50	97	17	415	1,260	5	5,800
SN0055	55	115	18	483	2,000	5	10,100
SN0060	60	115	18	483	2,000	5	13,400
SN0065	65	140	18	575	3,000	2	17,200
SN0070	70	140	18	575	3,000	2	23,100
SN0075	75	140	18	575	3,000	2	26,300

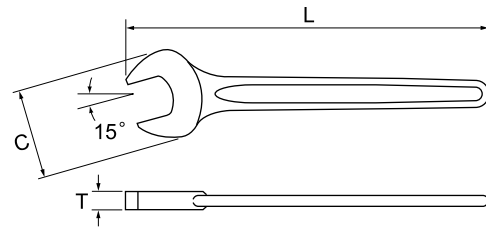

• Cathodic Electrodeposition  JQA (~ 0070)

## SN Double Open End Spanner, Metric

Code	mm	C <sub>1</sub> mm	C <sub>2</sub> mm	T mm	L mm	Weight g		Price ¥
SN0507	5.5×7	16	19	3.5	102	20	20	540
SN0607	6×7	16	19	3.5	102	20	20	540
SN0708	7×8	17	21	4	105	25	20	540
SN0809	8×9	19	21.5	4	115	30	20	540
SN0810	8×10	19	21.5	4	115	30	20	540
SN0910	9×10	19	21.5	4	115	30	20	540
SN1012	10×12	21.5	26	4.5	125	40	20	540
SN1013	10×13	23	27.5	5	130	50	20	540
SN1014	10×14	25	31.5	5.5	140	70	20	620
SN1113	11×13	23	27.5	5	130	50	20	580
SN1214	12×14	25	31.5	5.5	140	70	20	580
SN1317	13×17	32	37.5	6	160	100	20	650
SN1417	14×17	32	37.5	6	160	100	20	650
SN1618	16×18	37.5	41.5	6.5	180	100	20	730
SN1719	17×19	37.5	41.5	6.5	180	140	20	760
SN1921	19×21	40	46	7.5	195	170	20	960
SN1922	19×22	40	46	7.5	195	170	20	970
SN1924	19×24	44	50	8.5	215	220	20	1,140
SN2123	21×23	44	48.5	8	205	200	20	1,240
SN2126	21×26	46	55	9	225	280	10	1,240
SN2224	22×24	44	50	8.5	215	230	20	1,220
SN2326	23×26	46	55	9	225	280	10	1,580
SN2427	24×27	50	56	9.5	235	330	10	1,650
SN2430	24×30	50	60	9.5	257	360	10	1,830
SN2730	27×30	56	65	10.5	265	440	10	2,010
SN3032	30×32	63	66	11	275	510	10	2,640
SN3236	32×36	66	74	12	305	650	10	3,260
SN3541	35×41	74	83	14	345	930	5	4,110
SN3641	36×41	74	83	14	345	950	5	4,850
SN4146	41×46	87	97	16	385	1,450	5	6,900

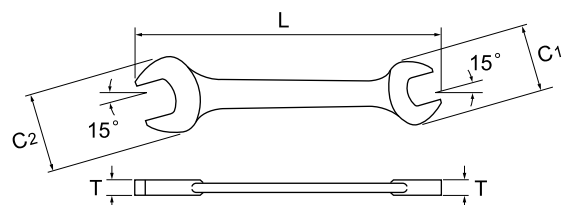

• Cathodic Electrodeposition  JQA

TOOL SETS

SPANNERS

STRIKING FACE WRENCHES

HOOK SPANNERS

DX2000 TOOLS

HEXAGON KEY WRENCHES

TORQUE WRENCHES

CROWFOOT WRENCHES

SOCKETS

OTHER TOOLS

